

LS C&S Busduct System

# I-series

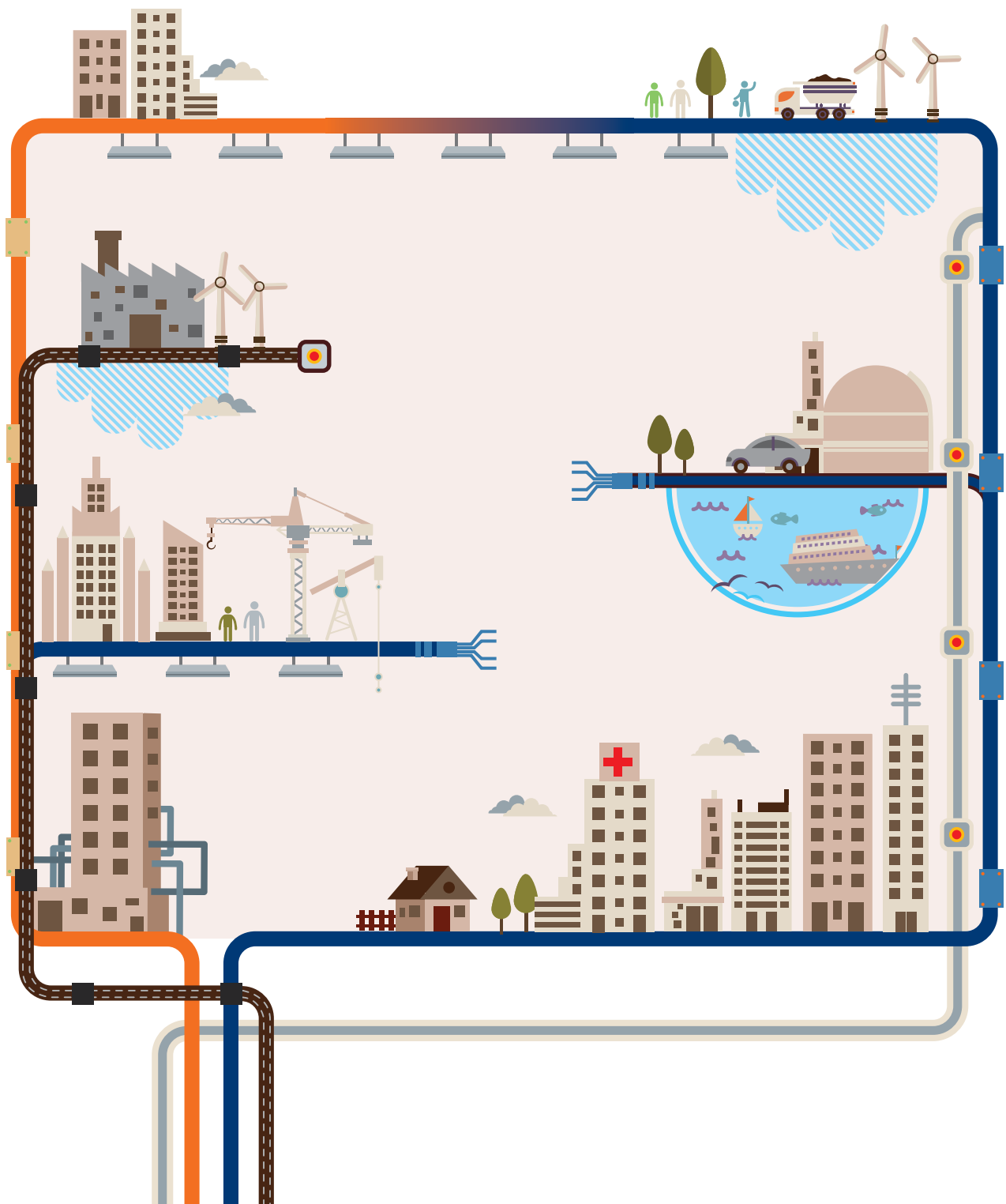

# About LS Cable & System

LS spun off from LG in 2003 as a group specializing in the Electrics, Electronics, Energy, and Material. LS consists of about 40 affiliates including LS Cable & System, LSIS, LS-Nikko Copper, LS Mtron, Gaon Cable, E1 and Yesco. A leading player in the global cable industry, with over half a century of experience as a manufacturer, providing consolidated expertise in the design and production of premium quality cabling technologies.



## Total Solution Provider for Electric Power and Telecommunication Industries

LS Cable & System, the longtime de facto holding company of LS Group, officially transformed into a holding company in July of 2008. The company's operations now encompass a total solution for electric power and telecommunication industries.

The latest change in corporate structure comes as the company is accelerating efforts to improve management efficiency in rapidly expanding markets. The move also results from efforts to effect a more responsible and transparent management structure. Management is now prepared to take more aggressive action to enhance our businesses and to identify new growth engines. The holding company will take the lead in fostering new growth engines and in identifying lucrative investment opportunities, while the company's other business units will focus on improving management and on making operations more efficient. With the continued support of the holding company, LS Cable & System will spearhead efforts to strengthen our business expertise, corporate competitiveness and management.



LNG, CNG



Supply of LPG for residential&commercial, transportation, industrial and petrochemical uses in domestic market. Import & Export of LPG etc.

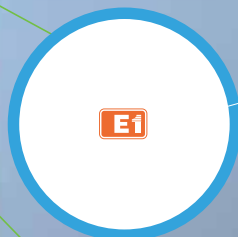

Components, Machinery



Control Cable, Power Cable, Elevator Cable, etc



Electrolytic Copper Cathode, Gold, Silver, Chemicals Product etc.

## Enable the Cabled World!!

LS Cable & System, established in 1962, has been contributing to building power grids and communication networks first in Korea and then in countries all over the world by developing, producing and providing cables and related solutions used in daily life and throughout many industries. Furthermore, the company set the stage for industrial and economic development by capitalizing on our innovative technology to supply various special industrial cables and industrial materials.

We at LS Cable & System are now supplying state-of-the-art products, such as submarine, extra-high voltage, high temperature superconducting and communications cables to power authorities, heavy electric equipment makers and common carriers around the world. Our products can be seen throughout the Americas, Europe, the Middle East and Asia, so we are now recognized as a leading manufacturer serving global industries both in name and reality.

Based on our corporate philosophy, "LS Cable & System Way," we will go beyond simply generating profits to develop forward thinking competencies by innovating our business models, developing environment-friendly high-quality products and reinforcing our partnerships with stakeholders as the best partner that will maximize customer values. We will open a brighter future by innovating and investing in technologies that push the envelope and developing the best total solutions.



**LS** Cable & System  
Leading Solution

# LS Cable & System Busduct System Solution



## *Buildings*

The LS C&S Busduct system is easy to install, and ensures large capacity of energy transmission while providing space efficiency which makes the bus duct system ideal for high-rise buildings, office buildings, data centers and apartment complexes.



## *Plants*

The full lineup consists of NSPB, CAST RESIN and SIB that can cover up to 27kv, and the lineup thus enables us to provide our clients customized designs. The system is suitable for electrical rooms and power lines, and it features a real time monitoring system using the temperature and power monitoring system.



## *Data Center*

The flexibility and expandability as well as easy maintenance property of the busduct system provides the best alternative to improve the existing problems of the conventional power cable system of data centers, which requires constant extension, reinstallation and capacity modification of loads.



## *Apartment Buildings*

Although the demands for more electricity for families are growing, the space for EPS area has reduced. Due to the change, the need for busducts and multi boxes have increased.



## *Hospitals*

The stability of the power supply in the hospitals is perhaps the most vital element, because its failure could threaten the safety of patients.

The Busduct system distributes larger capacity of electric power, and provides stability of the loads which make it an ideal choice to satisfy the requirements of systematization of hospital complexes and larger hospital equipments.



## *Airports*

In order to secure the stable power supply of the airport, the busduct system provides the best customized solutions by installing high voltage busducts at the transmission, transformation and power distribution lines, and by installing low voltage busducts at the cargo, the control tower and general commercial buildings.



## *Stadiums*

The needs for a busducts system has been growing for its benefit such as large capacity of power transmission, providing a stable power supply for various loads and an eco friendly property as well as economical quality.



## *Marine & Wind*

The compact and light weight design of the busduct satisfies the demands of the clients, and comes with an outstanding quack resistance property. The busduct provides stability to the operation of the facilities through a real-time monitoring system using a temperature and power monitoring system. As the needs for renewable energy grows, the demand for our busduct has been increasing steadily.



The LS Cable & System Busducts are available in a wide range of products from low current capacity LT-way (25A~63A) to large current capacity (630A~6300A), and the products enable the supply of proper capacity of power for factories and the distribution system. Our products such as the air insulated bus conducts with enhanced safety property and the cast resin busducts with resistance for high temperature, humidity and dusty environment will satisfy various application needs and provide a customized engineering service.

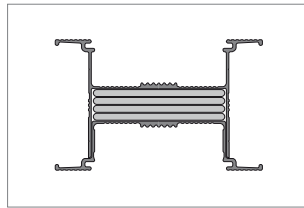
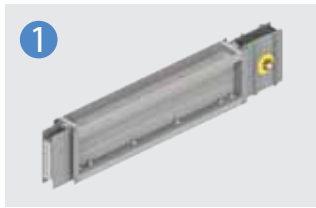

### **Iz/Ix/If-way**

Sandwich Type (PET Film, Epoxy Coating, MICA)/AL Extrusion Housing/Standard IP54/Joint Kit

- Designed for low voltage products below AC 1000V, and between 630A to 6300A.
- The most widely used conventional model.

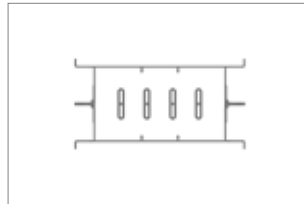
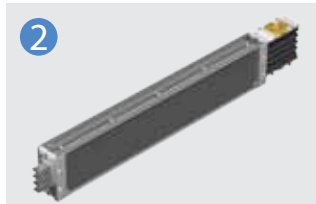

### **Mini-way**

Air Insulated Type/AL Extrusion Housing/Standard IP54/Joint Kit

- Designed for low voltage products below AC 1000V, and between 160A and 800A.
- Ideal for small distribution system with multi distribution loads (Vertical areas of buildings, data centers, assemble factories)

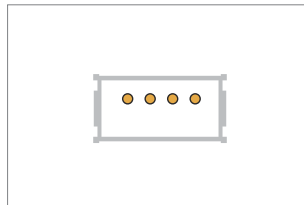

### **LT-way**

Flat Wire Type/Copper Conductor with PVC Extruded Insulation/AL Extrusion Housing/Various Plug Types/Joint Brush (It can be installed with a live wire.)

- Designed for low voltage products below AC 690V, and between 25A and 63A
- Suitable for Light bulbs, FFU and distribution for small equipments



### **MS/Wind-way**

Air Insulated Type/ Compact NSPB Type / One-Bolting Type Designed for low voltage products below AC 1000V, and between 1000A and 5000A

- A Hybrid incorporating NSPB and sandwich type
- Ideal for ships, wind towers and chemical plants where stability is required.

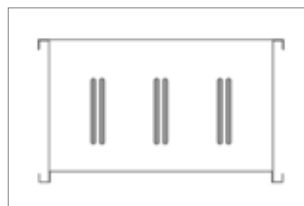

### **NSPB-LV/MV**

Air Insulated Type/Insulated conductors separated by phase/AL, STS and Steel Housing (optional)/Indoor Type/Outdoor Type

- NSPB-LV : Designed for low voltage products below AC 1000V, and below 4000A
- NSPB-MV: Designed for high voltage products below AC 27KV, and below 4000A
- Suitable for plants where high stability is required.



### **CR-LV/MV**

- Cast Resin Type/IP 68/Epoxy Molding between Conductors

- CR-LV: Designed for low voltage products below AC 1000V, and between 630A and 6300A.
- CR-MV: Designed for high voltage products below AC 27KV, and below 5000A.
- The most safe bus duct suitable for plants where high stability is required.

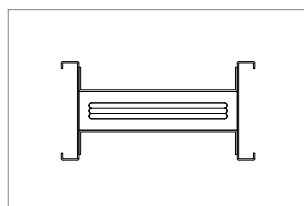

### **CR-LV-II**

- Cast Resin Type/IP 68/Epoxy Molding between Conductors and Housing

- AL Housing(Steel and SUS as optional)/Indoor/Outdoor
- Designed for low voltage products below AC 1000V, and between 630A and 6300A.
- Suitable for area with high humidity or rapidly changing temperature
- Easily jointed with Sandwich type Busduct

# Why Busduct?

## Easy Distribution of Loads

When supplying power using cables, each load has to be connected individually to cables which waste space, and an additional distribution panel is also required.

On the other hand, busducts are separated from a single line at a plug box which simplifies the electric power system. A MCCB can be installed at the plug box to effectively shut off fault current.

Cable Wiring System

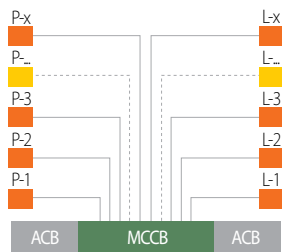

- One-to-one correspondence of power supply and loads
- Additional lines are needed in case of a load change

Busduct Wiring System

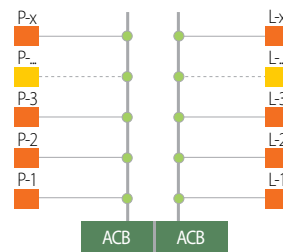

- One-to-many correspondence of power supply for specific power supply
- Additional lines are not necessary in case of a load change

ACB : Air Circuit Breaker, MCCB : Molded Case Circuit Breaker

## Easy Installation

Pulling and cable tray installation for cables can be difficult, and requires a longer construction period, therefore increases the cost. On the other hand, the busducts use a simple installation method to connect specific length of products, which requires a shorter installation period, and is economically friendly.

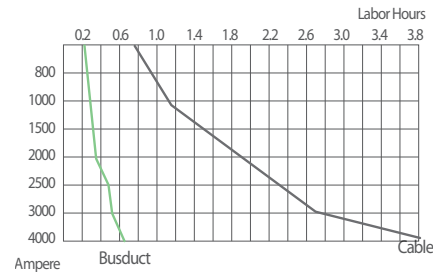

## Compact

The compact design of the busduct system provides high space efficiency at up to 50% compared to the cables. While cables require larger space to install multi lines as well as additional space for coiling areas, the busducts use proper fittings to maximize space efficiency.

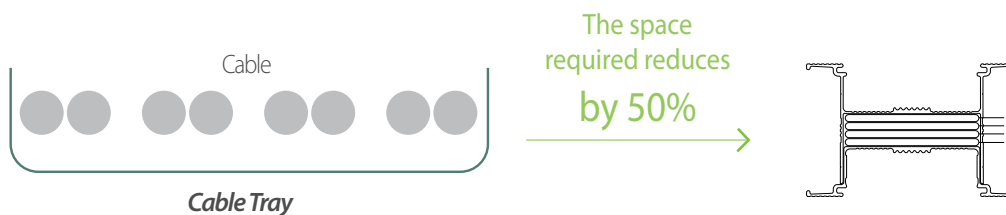



## Adaptability to various installation environment with convenience

The busduct system is a power distribution system and can be applied to various complex routes. The busduct system comes with various fittings such as elbow, off-set and tee, and can transmit high capacity currents without electrical and mechanical loss.

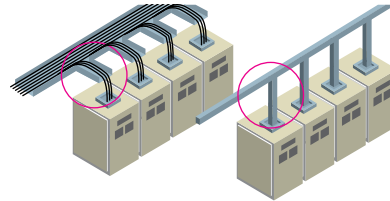

## Excellent short circuit strength

The busduct system has a high tolerance for short circuit. Its stability and reliability make it perfect for a high capacity energy transmission system.

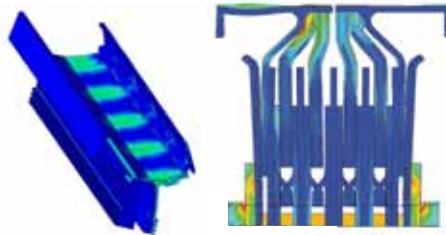

## High current density

Cables are connected directly to electric loads using racks. Its maximum allowable current ampacity limit is 1000A, and requires additional lines for a higher current. Each line of the busduct system can transmit up to 6300A, and provides high current density.

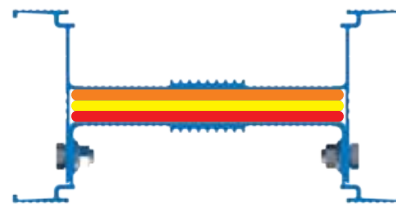

## Easy maintenance

The design of the busduct system makes it easy to detect abnormalities during installations, and ensures easy maintenance. When humidity or dust causes a malfunction on the system, the easy-to-maintain design allows replacing only the damaged part.

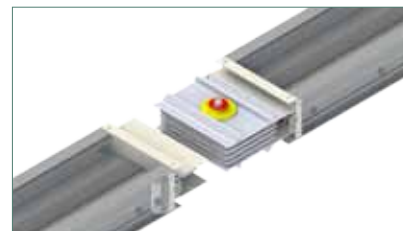

## Outstanding features of EMC and EMI

Unlike cables, the busduct system does not require a shield, instead Busduct, the housing itself performs as a shield which enhances the features of EMC and EMI.



# Why LS Cable & System Busduct

## Global Top Tier

LS Cable & System has been a long-time leading Busduct provider in Korea. With extensive experience and product line competitiveness, the company provides total solutions for each application to satisfy the needs of its clients. Using its expertise in the electronic markets of large LCD monitors and semiconductors in Korea, the company has obtained PJT sales records in 50 countries worldwide in Asia, the Middle East, CIS, and America.

## Full Line - up

LS Cable & System is the only global company that provides a full line-up of busducts, from low to high voltage and from low to high capacity, to satisfy every need of its clients and provide an optimized solution for each PJT.

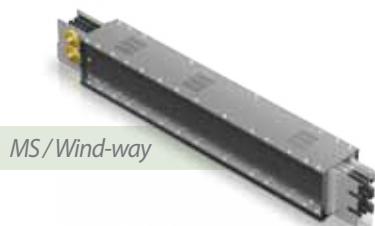

MS/Wind-way



LT-way

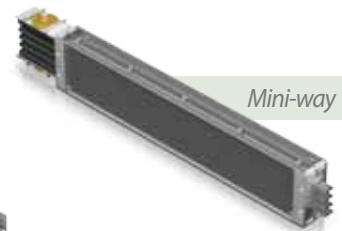

Mini-way

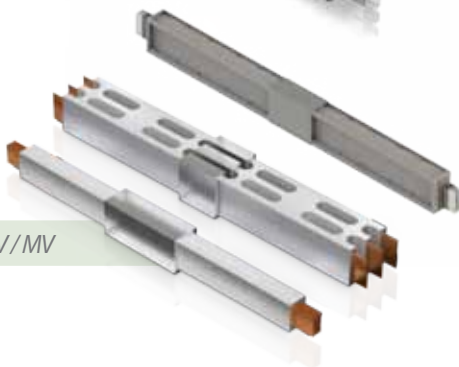

CR-LV/MV



Iz/Ix/Iy-way



NSPB-LV/MV

## Total Solution

- Once PJT launches, our engineer will participate to guide the clients from the initial period in order to produce the best system for our clients, and to respond quickly when the system is changed.
- Our engineers from each department provide full support in design, production, installation and testing at in-bound to satisfy our clients.
- We operate the CS Team, a task force for the busduct system, to make sure efficient after-sale service and maintenance service.

## Process

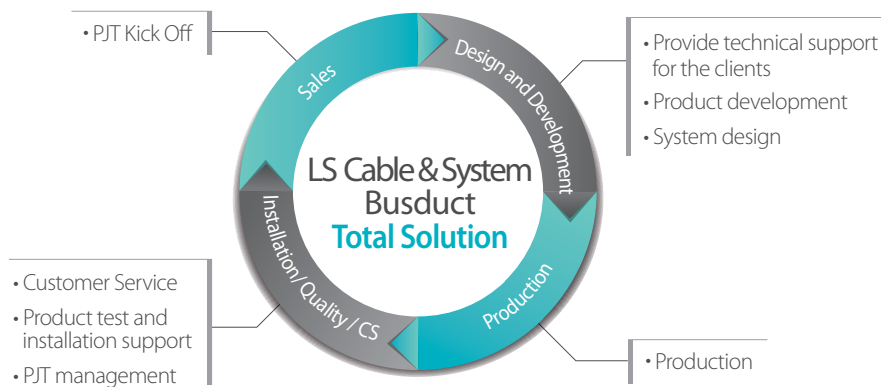

## Technical Excellence

### Unparalleled Reliability

- Provides standardized design, and owns numerous certifications such as UL Certification, Quack Proof Certification, and Impact Resistance Certification
- The CS team, a task force for the busduct system, provides efficient after-sale service
- Safe use in hazardous zones
- Manage the system using a unique temperature monitor sensor
- Semi-permanent service life
- Used qualified insulation such as epoxy and PET film for efficient insulation

### Eco friendly

- Fully recyclable
- Halogen free
- Does not contain RoHS 6 hazardous substance
- No toxicity in fire & Fire-Retardant
- Non Explosive

### Total Engineering Technology

- Provide the optimal design by experienced engineers
- Design following analysis and inspection of CAE
- Unique and exclusive design program for the busduct system
- Design based on structure stability inspection
- The excellent heat –radiating property of the aluminum housing, which ensures large capacity of power transmission
- Low Weight & Low cost
- Easy installation
- Deployable where access is difficult
- Automated epoxy insulation facility
- Unique joint kit connections
- Reduce electromagnetic
- BPMS (Busduct Power Monitoring system)
- BTMS (Busduct Temperature Monitoring system)

## The Busduct Temperature Monitoring System (BTMS : Busduct Temperature Monitoring System)

The busduct is a large capacity power distribution system. The insulation of the duct has to stay stable when the Joule lines occur during a power supply of the conductor. The rated current will be set by the insulation type and the temperature rises. These properties of the busduct make it possible to monitor and manage abnormalities of the system by checking the temperature of specific areas of the system.

The temperature monitoring system uses various temperature sensors such as optical fiber cable, IC electric chips and thermo-graphic cameras. Specific areas like the entire system line, joints, plug-in boxes and cable connection can be monitored at the central monitor room using various methods on request.

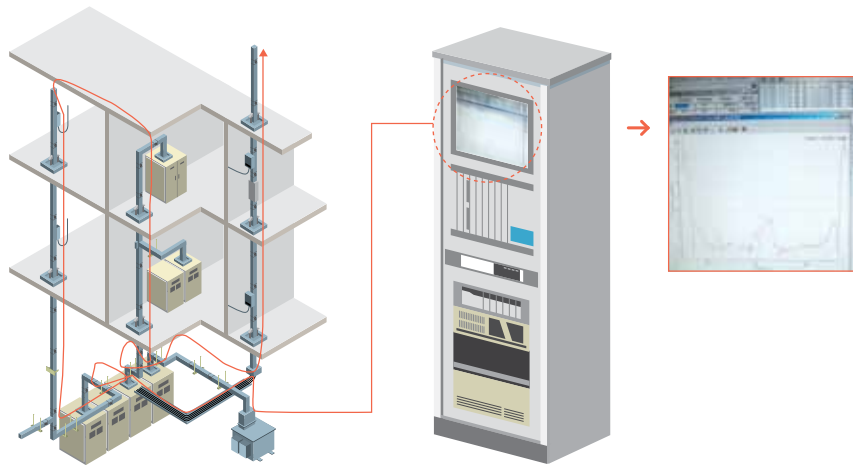

## The Busduct Power Monitoring System (BPMS : Busduct Power Monitoring System)

The ongoing trends of the busduct system are more than a simple power supplying system. The growing trend is; 1) the stability of the power system, 2) unmanned system, 3) cost cutting, and 4) green and smart grid. While the SCADA system monitors and controls the power of the main system, the BMS monitors low loads of the sub system. The frequency of the recent electrical accidents is higher at the sub system than at the main system. Therefore, the preference for the BMS system has been increasing.

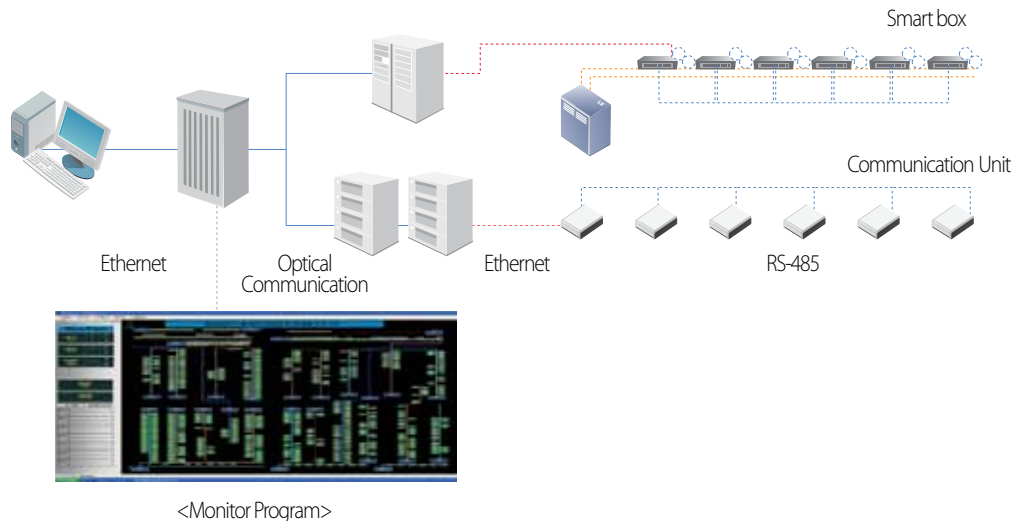

# Iz/Ix/If-way

LS C&S Busbuct System Catalogue

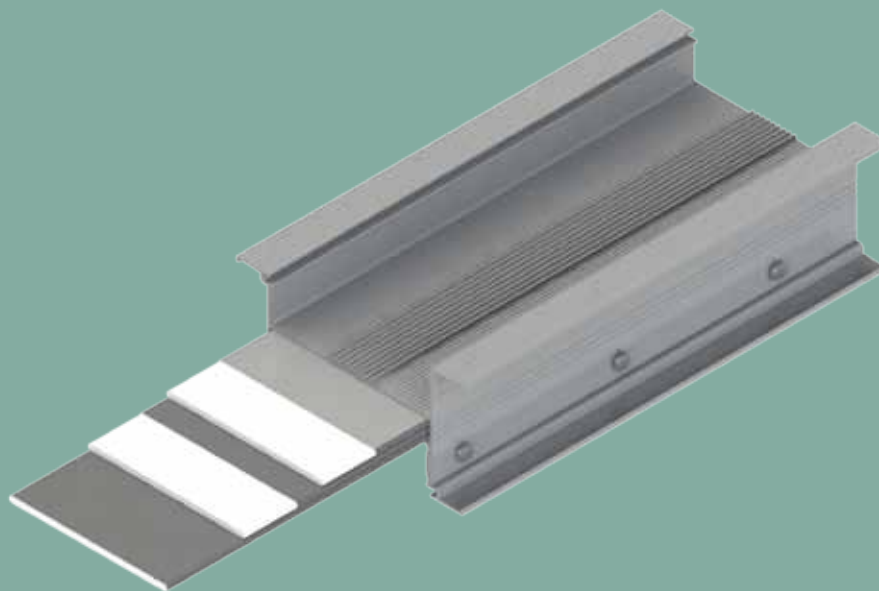

## Contents

<b>I. Introduction</b>	
- Overview .....	14
- Application .....	15
<b>II. General Data</b> .....	16
<b>III. Component</b>	
- Feeder .....	22
- Flanged End .....	23
- Fittings .....	26
- Hanger .....	29
- Plug-In Unit .....	31
- Etc .....	33
<b>IV. Technical Data</b>	
- Impedance .....	35
- Voltage Drop .....	35
- Temperature Rise .....	37
<b>V. Install Information</b>	
- Joint Connection .....	38
<b>VI. Certification &amp; Specification</b> .....	39

# Overview

## The I-Series

The LS C&S I-Series Busducts are designed to carry voltage range below AC 1000V, and to carry the current range of 630A to 6300A. Joint kit connections provide more space to connect which reduce the contact resistance to its minimum while connecting products. LS C&S I-series Busduct comes with a standard IP54 rating; however, it can be upgraded to an indoor or outdoor IP65 rating on request. I-Series Busducts have three different types of insulation using polyester film, mica film, or epoxy powder.

## Compact Size

LS C&S I-Series Busduct uses an effective heat radiating housing profile which allows the size of the conductors to be smaller than the existing Busduct models. The light weight of the Busduct also allows easier installation and requires less space.

## Economical and Easy Installation

LS C&S I-Series Busduct uses aluminum housing and joint kit connections which enable easy installation with less time and low cost.

## Easy Distribution of Loads

LS C&S I-Series Busduct can directly distribute the loads at the plug-in box using a single line, and thus simplifies the power supply system. The MCCB can be installed in the plug-in box on request to effectively shut off the faulty current.

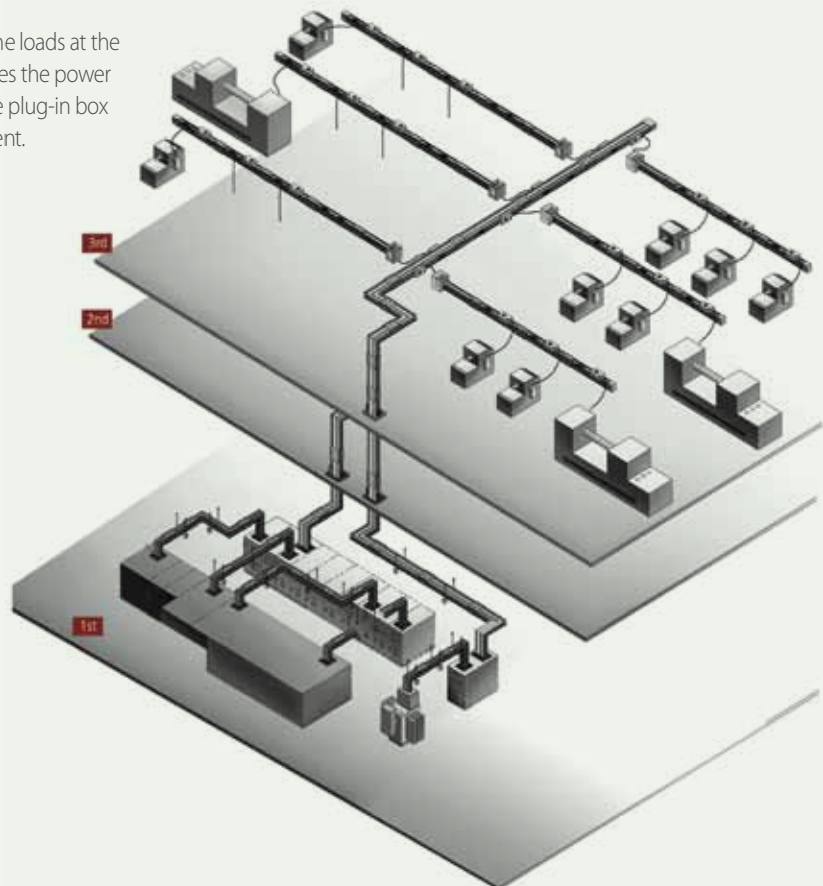

# Application



## Electrical Rooms

- The busduct can be installed both horizontally and vertically at the electrical room.
- The maximized safety features are seismic-proof and explosion-proof.
- Provides excellent space efficiency and easy installation compared to cables.

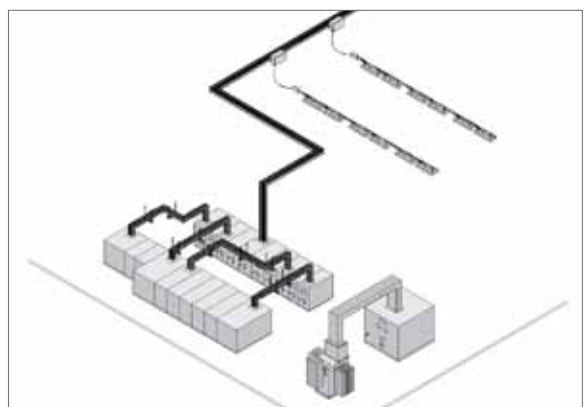

## Commercial / Housing Building etc.

- Provides excellent space efficiency.
- The busducts can be applied to high-rise buildings, office buildings, and data centers.
- Multi-box can be applied on request.

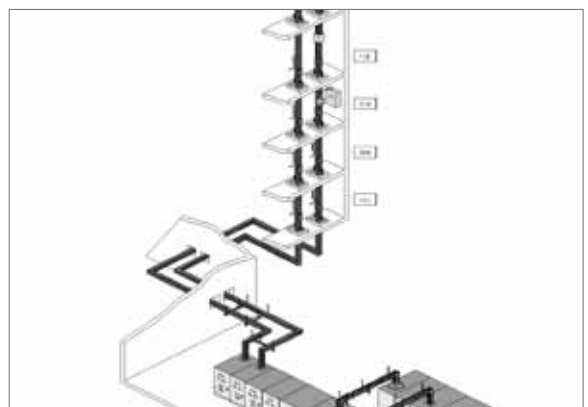

## Factory / Plant etc.

- The busducts can be applied to a vast range of industries such as semiconductor, display and petrochemical plants.
- The temperature and the power supply monitoring system allows easy maintenance.
- The busducts provides high space efficiency, and allows a significantly reduced installation period.

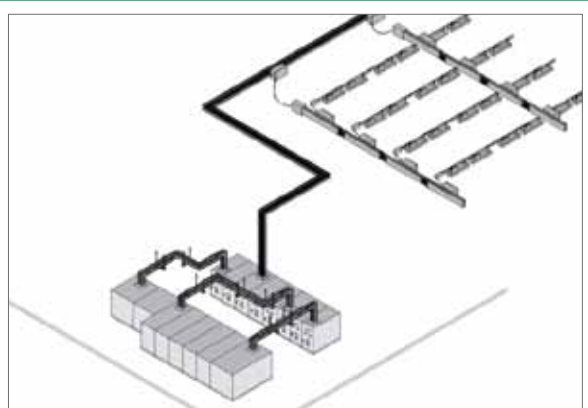

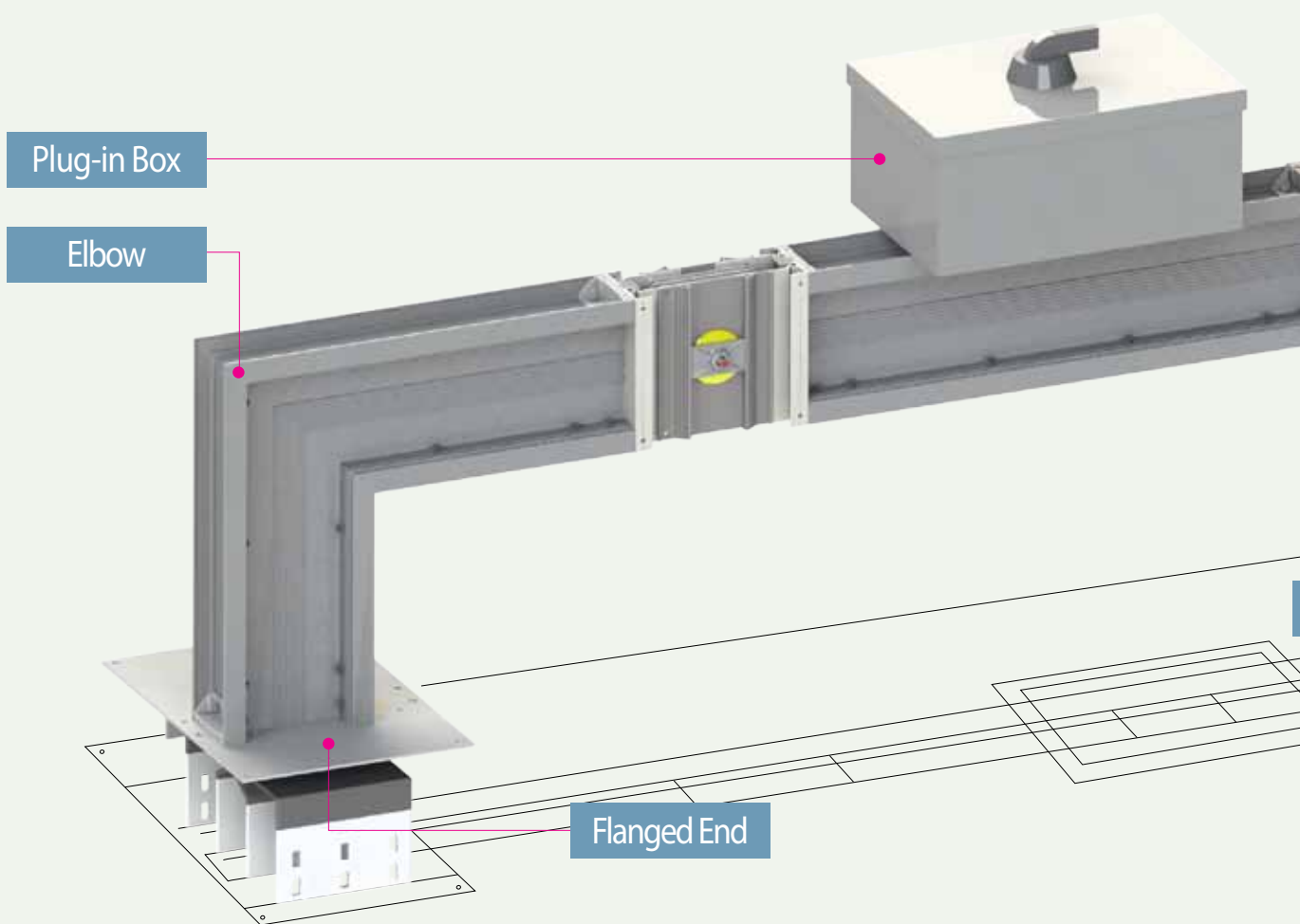

### High Current Density

The busduct has a compact design compared to the existing models by using an effective heat-radiating housing profile and can carry from 630A up to 6300A with reduced loss of electric power. It is an ideal power distribution system that provides high efficiency, stability, economy-friendliness and convenience. The design of the conductor allows flexibility to extend and relocate depending on the environment.



### Eco - Friendly

The LS C&S Busducts acquired RoHS certification, and only uses components without hazardous substances such as lead, cadmium, mercury, chrome, PBBs and PBDEs.



### Low Voltage Drop and High Short Circuit Strength

Thanks to the optimum design, power can be transmitted with the greatest possible efficiency, and the resultant voltage drop is low due to extremely low impedance. In addition, the LS C&S Busducts is designed to have high short circuit strength. Reinforced type is available. contact our engineering staff



### Standard

- IEC 61439-1 [(previous standard)IEC 60439-1] Power Switch gear and Control gear Assemblies
- IEC 61439-6 [(previous standard)IEC 60439-2] Busbar Trunking Systems
- BS EN 61439 Busways
- NEMA BU 1.1 Busways
- AS / NZS 3439.2



### Permissible Operating Temperature

The cross sectional areas of the conductor and housing profile are designed to meet the standard permissible operating temperature of IEC 61439-1 and 6. Therefore the temperature rise limit of the housing is within 55K or less of the ambient temperature.



### Service Condition

- Ambient Temperature : -15°C ~ 50°C
- Relative Humidity : 95% or below  
(When the service condition of the environment does not meet the requirements listed above, please contact our design team.)



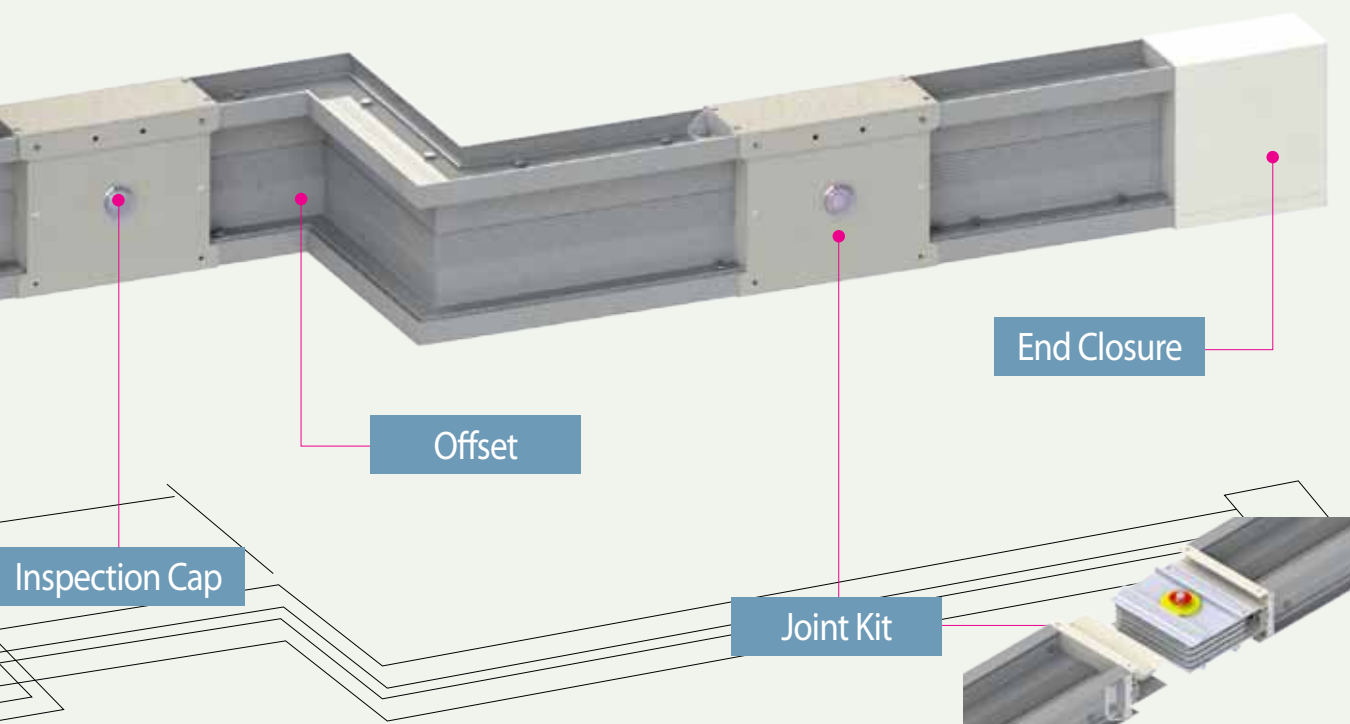

### Conductors

The I-Series uses either copper conductors with conductivity over 98% and purity over 99.9%, or aluminum conductor with conductivity over 61% and purity over 99.6%

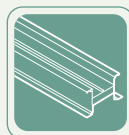

### Housing

The I-Series uses an effective heat-radiating aluminum housing profile which produces an excellent mechanical strength and heat radiation. The aluminum housing can be used as a protective conductor(PE) due to its high level conductivity and cross sectional areas. An optional optical fiber temperature sensor can be installed at the housing.

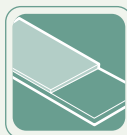

### Insulation Properties

An insulator of thermal class rating Class B(130°C) (Class F(155°C) optional) is applied to the I-Series. Other insulation options such as Epoxy, PET and MICA (Fire proof up to 1200°C) are also available. FRP (Fiber Reinforced Plastic) with high dielectric property is used as insulation at the connection which performs as insulation between phases and housing.



### Connection

- **Kit**: DH (dual head) bolts and Visible-label (Redtag)  
Check for installation using the contact  
To exert a uniform force on the entire connection can Disc Spring A structure. (Assembly Torque 800 ~ 1000kgf.cm)

# General Specifications

I-series Busduct uses insulation with a thermal class rating over 130°C for each phase. A sandwich type design is applied to the Busduct to protect the aluminum housing, and it can be used at the voltage range of AC 1000V or less, and the current range between 630A to 6300A. It is designed to use a joint kit connection and general IP54 rating.

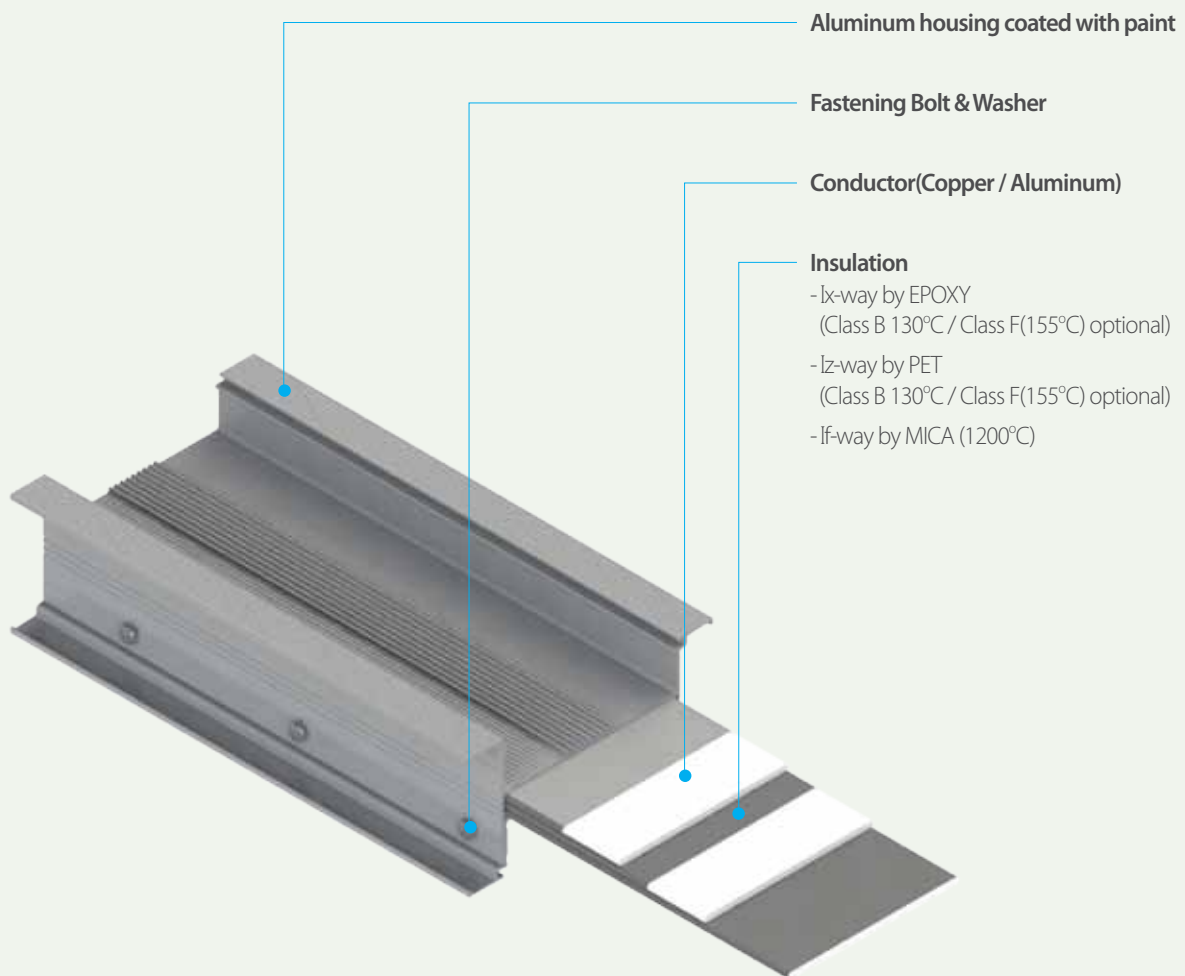

# Joint Connection

## Feature

Both joint plates of the joint kit and the conductors are tin plated. (A silver plated option is available.)

It prevents the joint plate from discoloration and corrosion. In order to ensure easy maintenance and reliability, double-headed bolts and visible labels are used to check the application, and a disc spring allows even connection of the contact surface.

## Double Headed Bolts

Double-headed bolts are used to ensure a proper torque level when installing the joint kit.

If a torque wrench applies a pressure of 800 to 1000kgf.cm to the outer bolt head, the head of the outer bolt and the tag attached to it will be sheared off automatically.

Thus, it allows visual inspection for the proper application of the bolts at the connection.

The remaining bolt head can be re-used when tightened to 800kgf.cm using a torque wrench.

After installing joint cover, red line at the end of double headed bolt should be seen through the inspection cap.

## Joint Kit

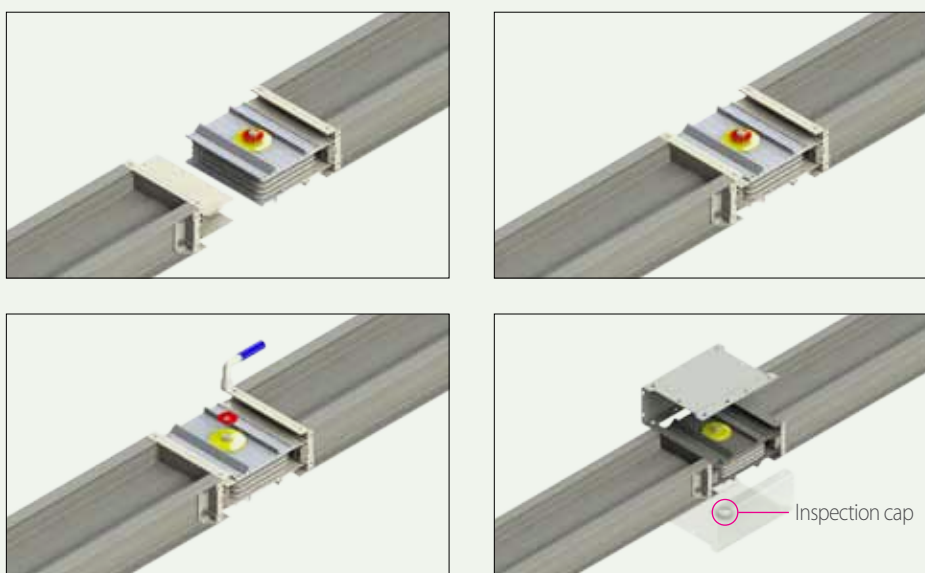

## Number of Double headed bolts

Number of D.H bolts		1	2	3	4	6
Ampere (A)	AL	630, 800, 1000, 1250, 1450, 1600	1850, 2000, 2250, 2500, 2900, 3200	-	3700, 4000, 4500	5000, 5800, 6300
	CU	630, 800, 1000, 1250, 1450, 1600, 1850, 2000	2250, 2500, 2900, 3200, 3700, 4000	5000, 5800	4500	6300

## ! Precaution

Be sure to clean the interior of the connections prior to installation. Use caution not to twist the joint kit while inserting it, and after it is inserted.

An excessive pressure during installation may break the kit.

Make sure that the double-headed bolts and the red tags are intact.

If proper torques are not applied at the connection, it may cause heat during operation.

# Grounding and Harmonics

I-Series Busduct comes with aluminum housing, and the cross-section area of the housing is over 100% of each phase conductor. Therefore, the aluminum housing alone works as 100% or more of ground bar, and the housing also improves the heat radiation of the conductors.

If increased ground capacity is required, additional internal ground bars can be added to the assembly, providing a 50% or 100% increase in ground path.

The 200% N type Busduct is used for a nonlinear load that generates harmonic current. Lately, the needs for non-linear loads at the power distribution system of buildings are increasing due to the increase of office automation and computer facilities. The harmonic current produced by the system can flow more than 100% of over current at phase N. The LS C&S 200% N type busduct is safe to be used at the distribution system where the harmonic current can be generated.

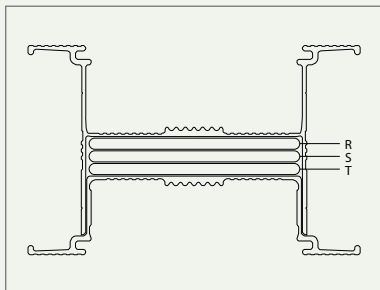

[3W+GE]

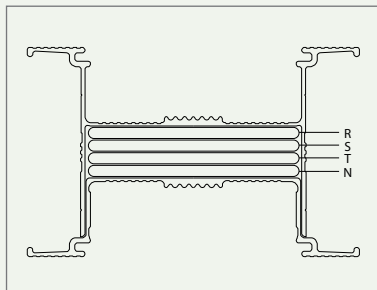

[4W+GE]

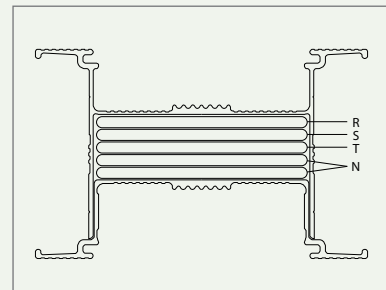

[4W(200%N)+GE]

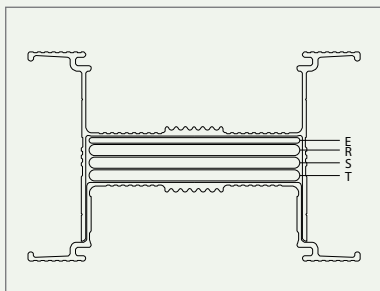

[3W+50%E, 100%E]

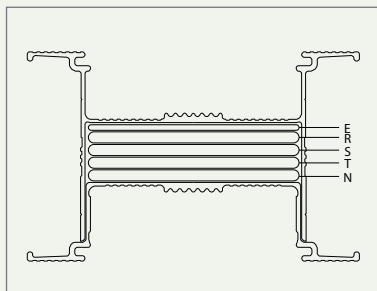

[4W+50%E, 100%E]

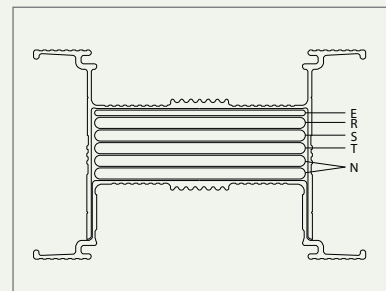

[4W(200%N) + 50%E]

# Plating/Painting

## Plating

Standard tin plating is applied at taps, plugs and connections of conductors using an electroplating method to maintain the electrical characteristics and to prevent corrosion. Silver plating is available on request.

## Painting

In order to improve heat radiation and to prevent corrosion, as well as to fit in with the surroundings, we apply polyester-epoxy (hybrid) power coating after treating the surface. A wide range of color is available to meet the needs of our clients.

\*Standard color : RAL 7032

# IP Code (Degree of Protection)







International protection degree codes provided by IEC 60529(Degree of Protection Provided by Enclosure-IP Code)

NEMA STANDARD : • IP54=NEMA 12, 12K, 13 • IP55=NEMA 3, 3X, 3S, 3SX • IP66=NEMA 4,4X • IP67=NEMA 6  
 \* As the standard differs, it is a similar substitution, not 1:1 substitution.









The degree of protection against water of the LS C&S I-Series is a standard IP54; however, it can be adjusted from IP42 to IP65 depending on the environment and on request.

## IP

### Solid Particle Protection

-  **0 No Protection**
-  **1** Protection against 50mm diameter solid particles. (back of a hand)
-  **2** Protection against 12mm solid particles. (fingers)
-  **3** Protection against 2.4mm solid particles. (tools or thick wires)
-  **4** Protection against 1mm solid particles. (tools or most wires)
-  **5** Protection against dust.
-  **6** Complete protection against dust.

### Liquid Ingress Protection

-  **0 No Protection**
-  **1** Protection against falling drops of water.
-  **2** Protection against falling drops of water with an enclosure tilted at a 15degree angle from a vertical line
-  **3** Protection against spray sat a 60degree angle from a vertical line
-  **4** Protection against water splashed from all directions.
-  **5** Protection against low pressure jets of water from all directions.
-  **6** Protection against strong jets of water from all directions.
-  **7** Protection against the effects of immersion between 15.0 centimeters and 1.0 meter.
-  **8** Protection against longer periods of immersion under pressure.

## Degree of Protection IP54

IP54 is applied to the feeder, plug-in and tap-off, and can be used during water leakages and near sprinklers.

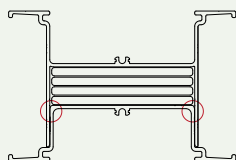

Indoor

## Degree of Protection IP55/IP65 (Indoor/Outdoor)

With the IP65 rating, the busduct is ideal for corrosive environments. The special sealing between the housing sections seals off water, dust and gasses.

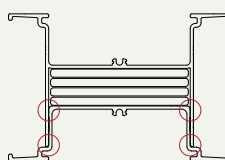

Indoor Type (IP55/65)

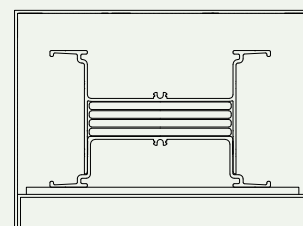

Outdoor Type (IP65)

# Feeder

## Sectional View

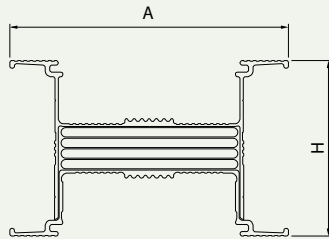

[Fig.E1-1]

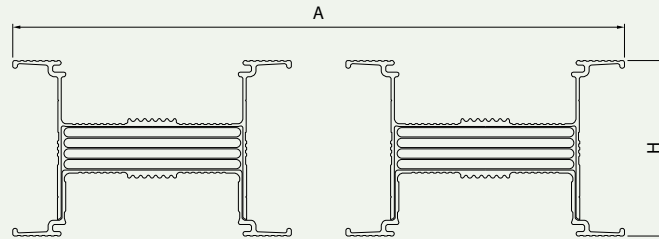

[Fig.E1-2]

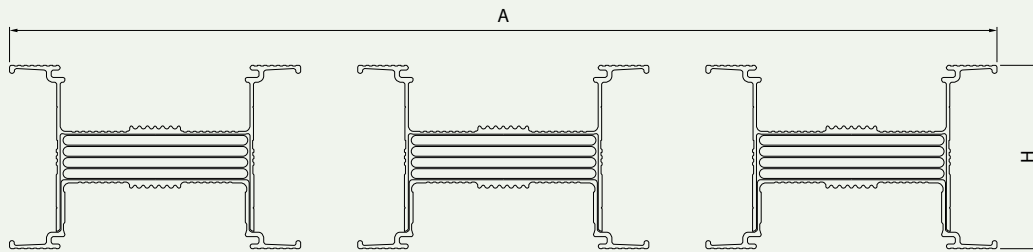

[Fig.E1-3]

AL Rating(A)	Dimension(mm)	Weight(kg/m)		CU Rating(A)	Dimension(mm)	Weight(kg/m)		Fig.
	A	3W	4W		A	3W	4W	
630	107	6.93	7.69	630	112	8.75	10.45	E1-1
800	117	7.77	9.13	800	127	10.41	12.54	
1,000	137	9.37	11.26	1,000	147	12.73	15.54	
1,250	162	11.45	13.95	1,250	147	17.62	22.05	
1,450	197	14.67	17.82	1,450	167	21.32	26.85	
1,600	207	15.61	19.20	1,600	177	23.05	29.11	
1,850	242	18.43	22.67	1,850	207	28.59	36.16	
2,000	252	19.27	23.91	2,000	217	30.66	38.84	
2,250	277	21.28	26.38	2,250	237	34.16	43.4	
2,500	357	23.42	27.74	2,500	327	36.25	45.43	
2,900	427	29.89	35.55	2,900	367	43.41	54.71	
3,200	447	31.74	37.97	3,200	387	47.01	59.42	
3,700	517	37.39	44.91	3,700	447	58.41	73.96	
4,000	537	39.15	47.20	4,000	467	62.34	79.01	
4,500	587	43.69	53.03	4,500	507	70.01	89.01	E1-3
5,000	747	53.12	63.77	5,000	642	80.44	101.61	
5,800	822	59.08	69.83	5,800	717	93.9	119.04	
6,300	897	65.03	75.90	6,300	777	104.49	132.85	

\* H: 107.5(3W+GE, 3W+50%E) / 115(4W+GE, 4W+50%E) / 130(4W+100%E)

\*\* According to IEC 61439, 5% more current can be used at a frequency of 60 Hz

# Flanged End

Flanged end is connected to either a transformer or panel. Dimension details are listed below.

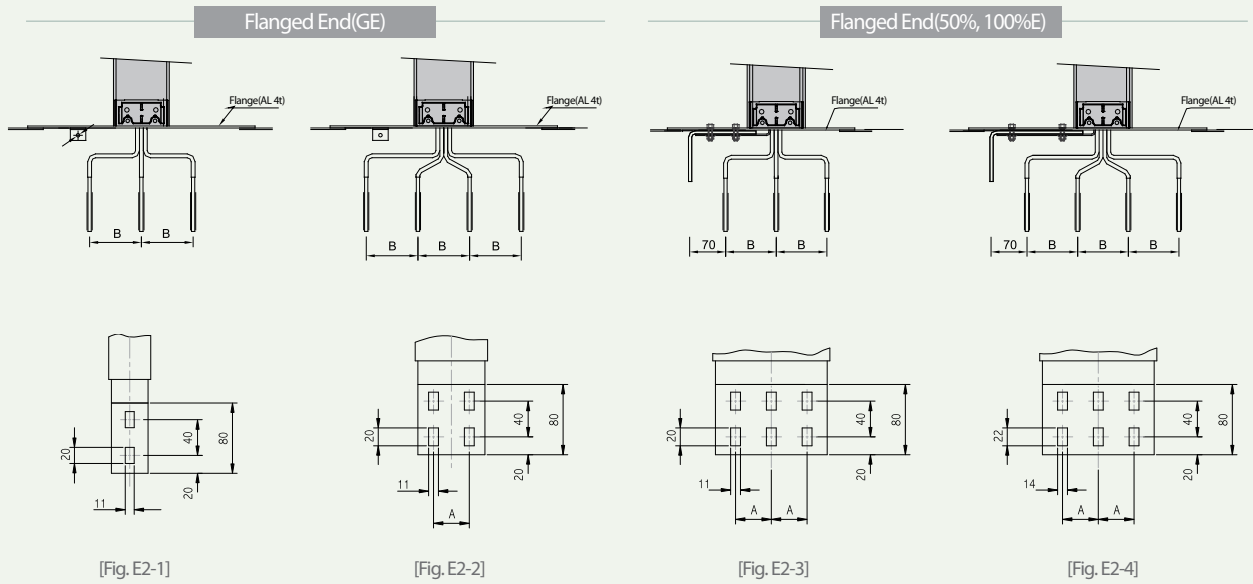

AL Rating(A)	Dimension(mm)		Fig.	CU Rating(A)	Dimension(mm)		Fig.				
	A	B			A	B					
630	-	100	E2-1	630	-	100	E2-1				
800	-			800	-						
1,000	40		E2-2	1,000	40		100	E2-2			
1,250	50			1,250	40						
1,450	40		E2-3	1,450	50			100	E2-3		
1,600	50			1,600	50						
1,850	60		E2-4	1,850	50				100	E2-3	
2,000	60			2,000	50						
2,250	70		E2-4	2,250	60					100	E2-4
2,500	50			2,500	40						
2,900	40	E2-3	2,900	50	130	E2-2					
3,200	50		3,200	50							
3,700	60	E2-4	3,700	50		130	E2-3				
4,000	60		4,000	50							
4,500	70		4,500	60			E2-4				
5,000	60		5,000	40							
5,800	60		5,800	50			E2-3				
6,300	70		6,300	60							

\* Contact our engineering staff for more detail

# Flanged End

## Drilling Pattern for Flanged End

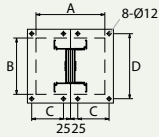

[Fig. E3-1]

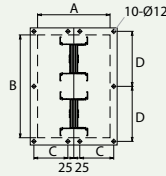

[Fig. E3-2]

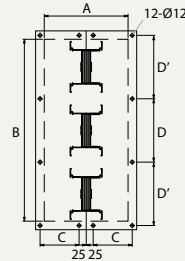

[Fig. E3-3]

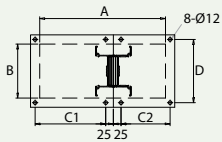

[Fig. E4-1]

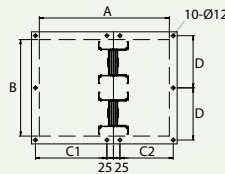

[Fig. E4-2]

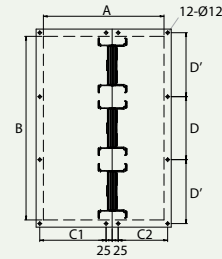

[Fig. E4-3]

Rating (A)	3WGE	3W, 4WGE	3WGE	3W, 4WGE	4WGE	3W, 4WGE	4WGE	3W, 4WGE	4W+50%E/100%E						Fig.			
	AL, CU	AL	AL, CU	AL	AL, CU	CU	AL, CU	CU	AL, CU	AL, CU	AL, CU	AL, CU	AL, CU	AL, CU				
	A	B	C	D	D'	A	B	C	D	D'	A	B	C1	C2		D	D'	
630	240	121	110	151	-	340	126	160	156	-	E3-1	410	121/126	230	160	151/156	-	E4-1
800	240	131	110	161	-	340	141	160	171	-		410	131/141	230	160	161/171	-	
1,000	240	151	110	181	-	340	161	160	191	-		410	151/161	230	160	181/191	-	
1,250	240	176	110	206	-	340	161	160	191	-		410	176/161	230	160	206/191	-	
1,450	240	211	110	241	-	340	181	160	211	-		410	211/181	230	160	241/211	-	
1,600	240	221	110	251	-	340	191	160	221	-		410	221/191	230	160	251/221	-	
1,850	240	256	110	286	-	340	221	160	251	-		410	256/221	230	160	286/251	-	
2,000	240	266	110	296	-	340	231	160	261	-		410	266/231	230	160	296/261	-	
2,250	240	291	110	321	-	340	251	160	281	-		410	291/251	230	160	321/281	-	
2,500	300	371	140	200.5	-	430	341	205	185.5	-	E3-2	500	371/341	275	205	200.5/185.5	-	E4-2
2,900	300	441	140	235.5	-	430	381	205	205.5	-		500	441/381	275	205	235.5/205.5	-	
3,200	300	461	140	245.5	-	430	401	205	215.5	-		500	461/401	275	205	245.5/215.5	-	
3,700	300	531	140	280.5	-	430	461	205	245.5	-		500	531/461	275	205	280.5/245.5	-	
4,000	300	551	140	290.5	-	430	481	205	255.5	-		500	551/481	275	205	290.5/255.5	-	
4,500	300	601	140	315.5	-	430	521	205	275.5	-		500	601/521	275	205	315.5/275.5	-	
5,000	300	761	140	261	265	430	656	205	226	230	E3-3	500	761/656	275	205	261/226	265/230	E4-3
5,800	300	836	140	286	290	430	731	205	251	255		500	836/731	275	205	286/251	290/255	
6,300	300	911	140	311	315	430	791	205	271	275		500	911/791	275	205	311/271	315/275	



## Flanged End Box / Feed in Box

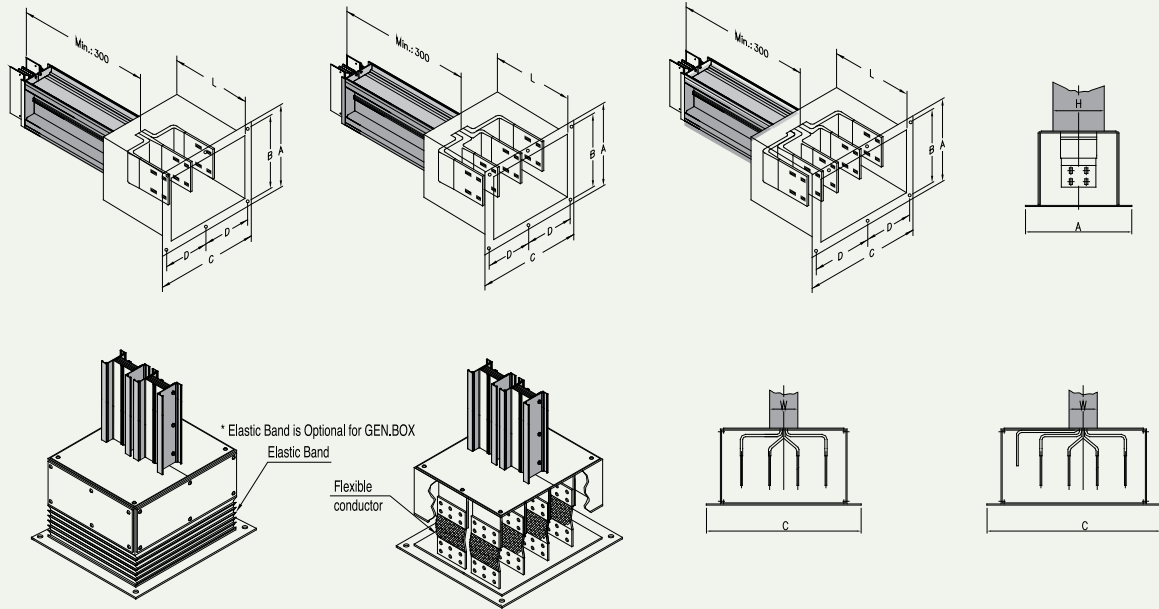

Rating (A)	3W, 4WGE	3W, 4WGE	3WGE	3WGE	3W, 4WGE	3W, 4WGE	4WGE	4WGE	4W+50%E/100%E			
	AL	AL	AL, CU	AL, CU	CU	CU	AL, CU	AL, CU	AL/CU	AL/CU	AL, CU	AL, CU
	A	B	C	D	A	B	C	D	A	B	C	D
630	346	296	410	180	351	301	510	230	346/351	296/301	580	265
800	356	306	410	180	366	316	510	230	356/366	306/316	580	265
1,000	376	326	410	180	386	336	510	230	376/386	326/336	580	265
1,250	401	351	410	180	386	336	510	230	401/386	351/336	580	265
1,450	436	386	410	180	406	356	510	230	436/406	386/356	580	265
1,600	446	396	410	180	416	366	510	230	446/416	396/366	580	265
1,850	481	431	410	180	446	396	510	230	481/446	431/396	580	265
2,000	491	441	410	180	456	406	510	230	491/456	441/406	580	265
2,250	516	466	410	180	476	426	510	230	516/476	466/426	580	265
2,500	596	546	470	210	566	516	600	275	596/566	546/516	670	310
2,900	666	616	470	210	606	556	600	275	666/606	616/556	670	310
3,200	686	636	470	210	626	576	600	275	686/626	636/576	670	310
3,700	756	706	470	210	686	636	600	275	756/686	706/636	670	310
4,000	776	726	470	210	706	656	600	275	776/706	726/656	670	310
4,500	826	776	470	210	746	696	600	275	826/746	776/696	670	310
5,000	986	936	470	210	881	831	600	275	986/881	936/831	670	310
5,800	1061	1011	470	210	956	906	600	275	1061/956	1011/906	670	310
6,300	1136	1086	470	210	1016	966	600	275	1136/1016	1086/966	670	310

# Fittings

I-Series Busduct has a wide range of fittings to satisfy any layout of buildings. Elbow angles other than 90° are also available. Fitting designs are shown in the following figures, and they consist of the source-side and the load-side. Offset or combination elbows can be used where standard elbows are not feasible. (Dimensions for each fitting are shown in the following figures. Contact our design team for a minimum dimension.)

## Elbow

[Horizontal]

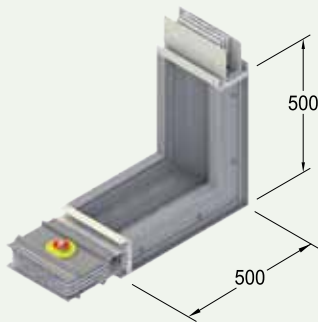

[Vertical]

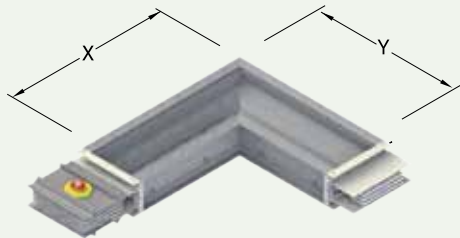

## Offset

[Horizontal]

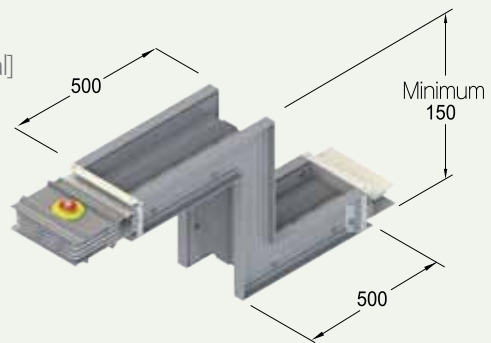

[Vertical]

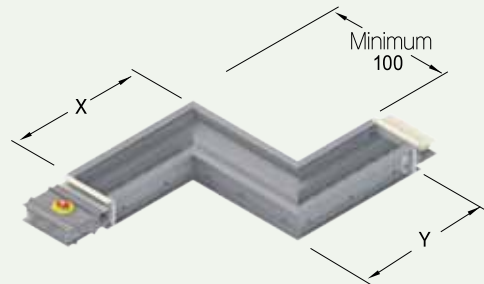

## Vertical Elbow

	Ampere(A)	Dimension(mm)	
		X	Y
AL	630~1,450	500	500
	1,600~2,900	600	600
	3,200~4,000	700	700
	4,500~5,000	800	800
	5,800~6,300	900	900
CU	630~2,000	500	500
	2,250~3,700	600	600
	4,000~5,000	700	700
	5,800~6,300	800	800

## Vertical Offset

	Ampere(A)	Dimension(mm)		
		X	Y	Z
AL	630~1,450	500	150	500
	1,600~2,900	600	150	600
	3,200~4,000	700	150	700
	4,500~5,000	800	150	800
	5,800~6,300	900	150	900
CU	630~2,000	500	150	500
	2,250~3,700	600	150	600
	4,000~5,000	700	150	700
	5,800~6,300	800	150	800

## Combination

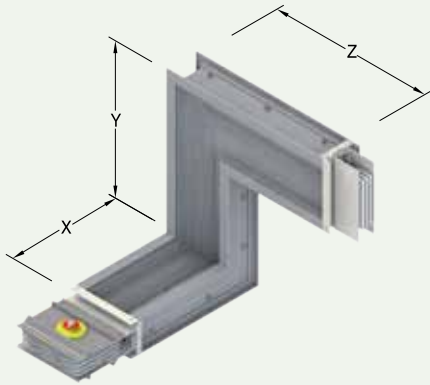

Rating(A)		Dimension(mm)		
		X	Y	Z
AL	630~1,450	500	500	500
	1,600~2,900	600	600	600
	3,200~4,000	700	700	700
	4,500~5,000	800	800	800
	5,800~6,300	900	900	900
CU	630~2,000	500	500	500
	2,250~3,700	600	600	600
	4,000~5,000	700	700	700
	5,800~6,300	800	800	800

## Tee

[Horizontal]

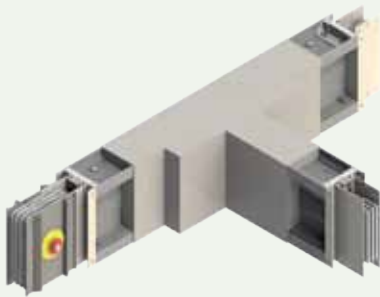

[Vertical]

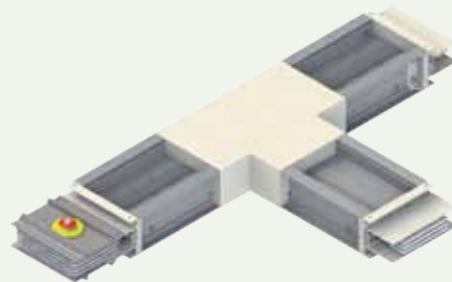

## T/R Connection Feeder



# Fittings

## Expansion

The fitting is designed to allow a 60mm extension of a straight line.

Rating	Standard Dimension(mm)	
	X	Y
630~6,300A	1,500	360

\*Flexible bars installed inside

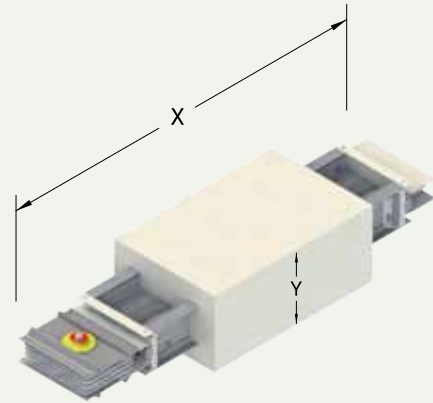

## Reducer

A reducer is used to connect a large capacity busduct to a small capacity busduct. It can be used for an economical setup to distribute loads.

\*Any change made to load distribution or to capacities follows electricity regulations.



## Reducer Box

If an overcurrent breaker needs to be mounted on the reducer by customer request, it is possible to use the reducer box.



## Phase Transposition Feeder

A phase transposition feeder is used when the setup transforms the phase.

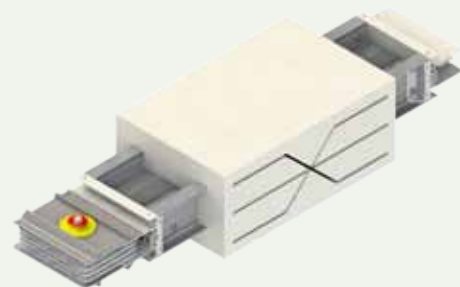

# Hanger

## Vertical Mounting Hangers

Spring hangers are used to support the busducts between floors. The number of springs depends on the weight of the installed busduct and plug-in boxes. A medium hanger should be installed if the height between the floors exceeds 4.5 meters, and the height of the installed spring hangers can be easily adjusted. Rigid hangers (no spring type) are used on the lowest floor, and they can be used instead of spring hangers depending on the set up design.

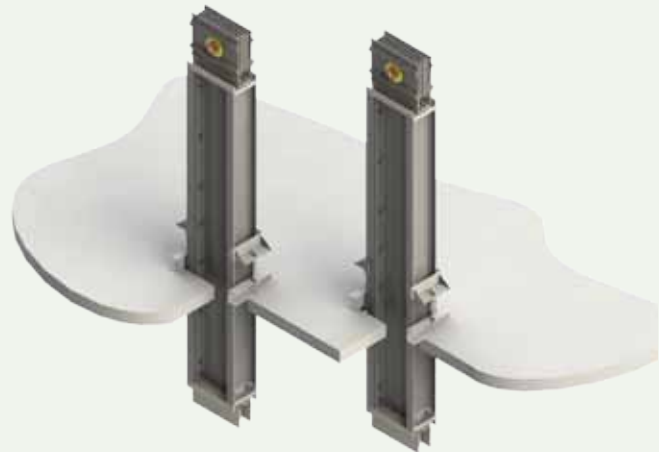

[Rigid Hanger]

[Spring Hanger]

### Rigid Hanger

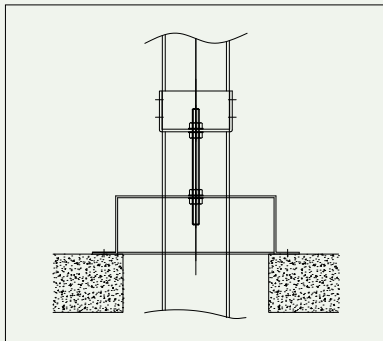

[1 Row]

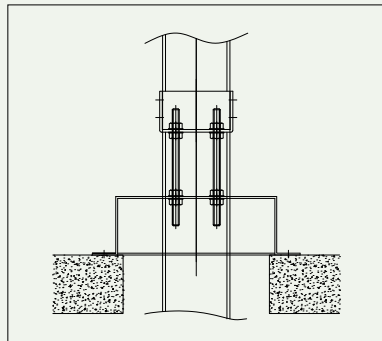

[2 Row]

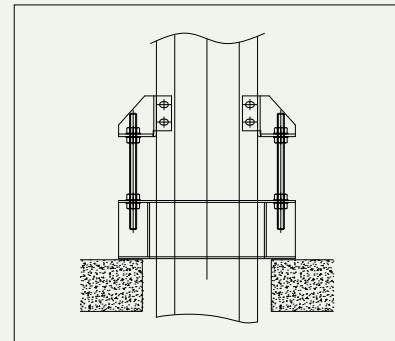

[Side View]

### Spring Hanger

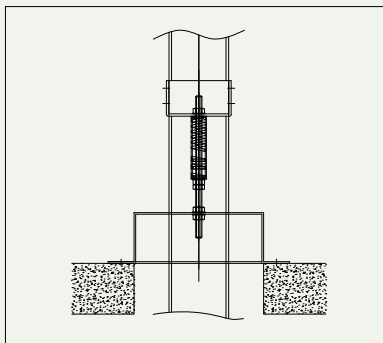

[1 Row]

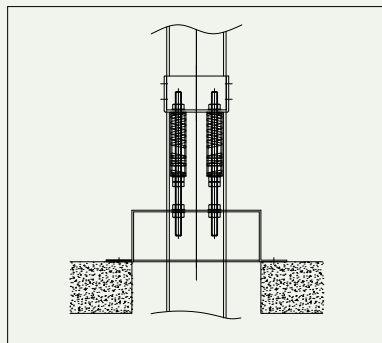

[2 Row]

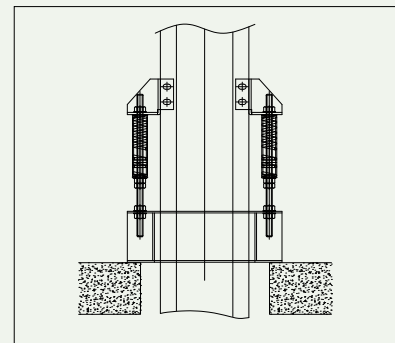

[Side View]

\* Hangers with more than 2 rows depending on the installation environment are also available on request. Please contact the design team for further information.

# Hanger

## Horizontal Hangers

### General Hangers

The standard installation method for these hangers is to install them horizontally at 1.5 meters intervals. They generally require 12mm diameter stud bolts.

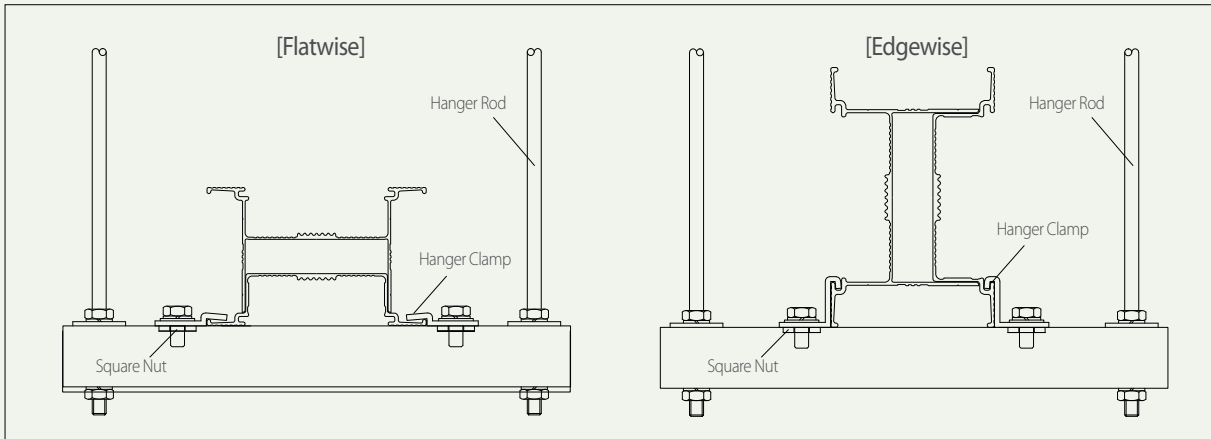

### Wall Bracket

Wall brackets can be installed on a wall where general hangers are not feasible.

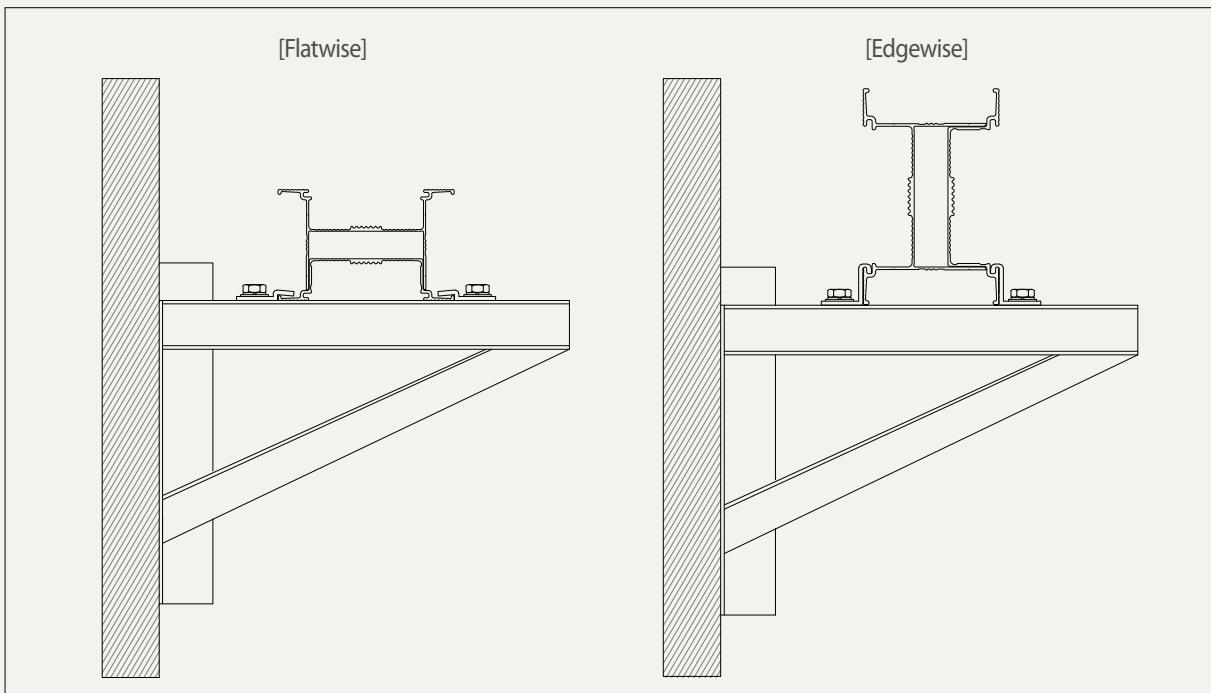

# Plug-in Unit

## Straight Lengths: Plug-in / Tap-off Intervals

This busduct comes with an overcurrent blocking device (MCCB, fuse) in order to protect the wires while distributing loads. The required minimum intervals of a plug-in(800A or less) and a tap-off(1000A, 1250A, 1600A) are shown below. A length longer than the required minimum intervals can be predestinated on request.

### Plug-in Feeder

MCCB Frame (AF)	Plug-in Hole Intervals(P) (mm)
50, 125, 250	650
400	900
630, 800	1,000
1000, 1250	1,300

### Plug-in Box

MCCB Frame (AF)	Dimensions(mm)				Fig.
	W		D	H	
125	200	230	200	360	E5-1
250	200	230	200	360	
400	230	280	200	800	
630, 800	300	370	200	800	
1000, 1250, 1600	400	450	230	1200	E5-2

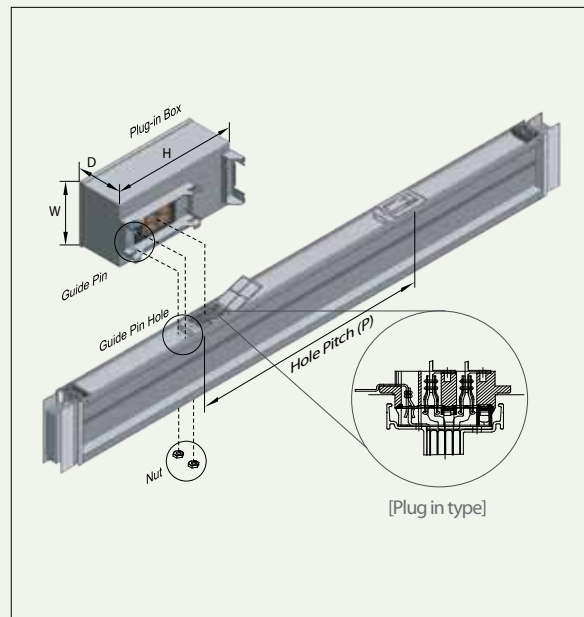

[Fig. E5-1]

### Inspection Pin

This pin is used to check the insertion of the box.  
\*Available from 400AF box



[Before]



[After]

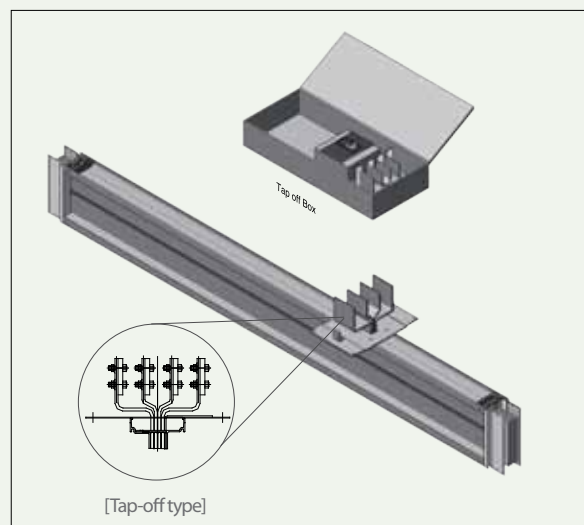

[Fig. E5-2]

# Plug-in Unit

## Plug-in Box Attachments

Attachments such as CT,TD and PT can be installed in a plug-in box to control and to supervise the current, voltage and wattage remotely.

## Door Types of the Plug-in Unit

Various design of doors for the plug-in box is available to satisfy the demands of our clients. The available types are shown below.

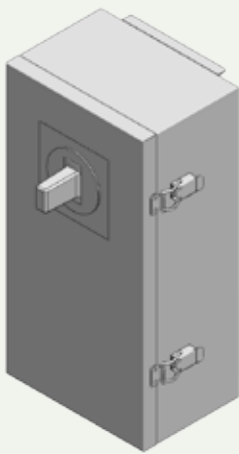

External handle

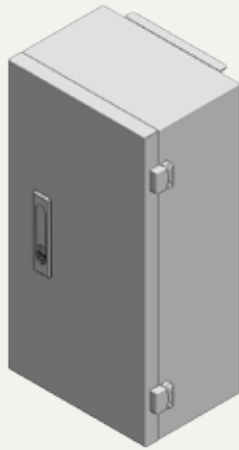

Push Button

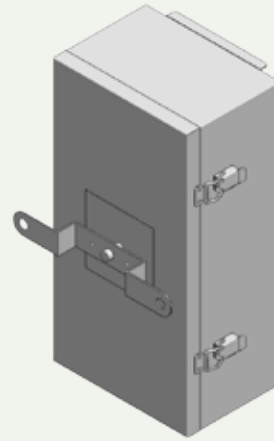

External lever interlock



Bolt Fastening

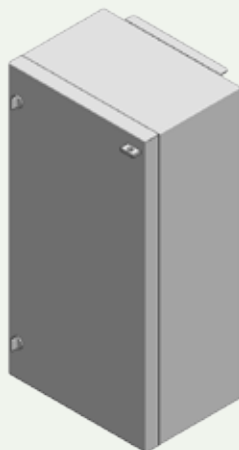

Key Lock



Outlet



# Etc.

## Wall Flange

A wall flange is used to seal the gaps produced during installation of busducts at the walls, ceilings and floor. The standard dimensions of a wall opening should be 30mm larger than the external dimensions of the I-Series Busduct.

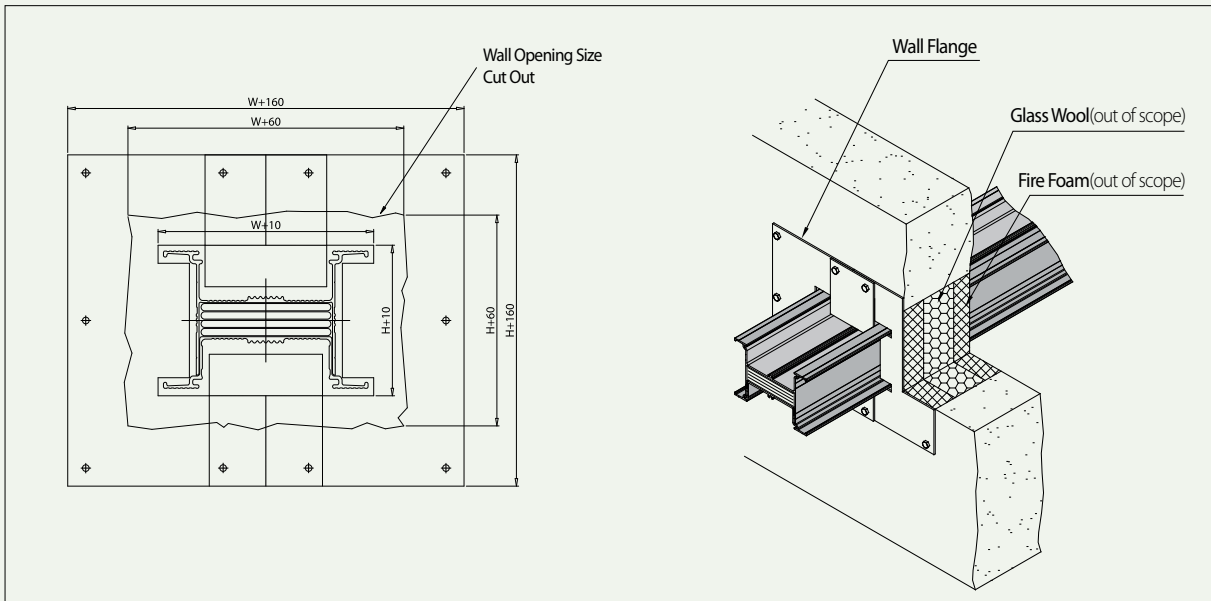

## Floor Openings

The standard dimensions of a floor opening should be 30mm larger than the external dimensions of the I-Series Busduct.

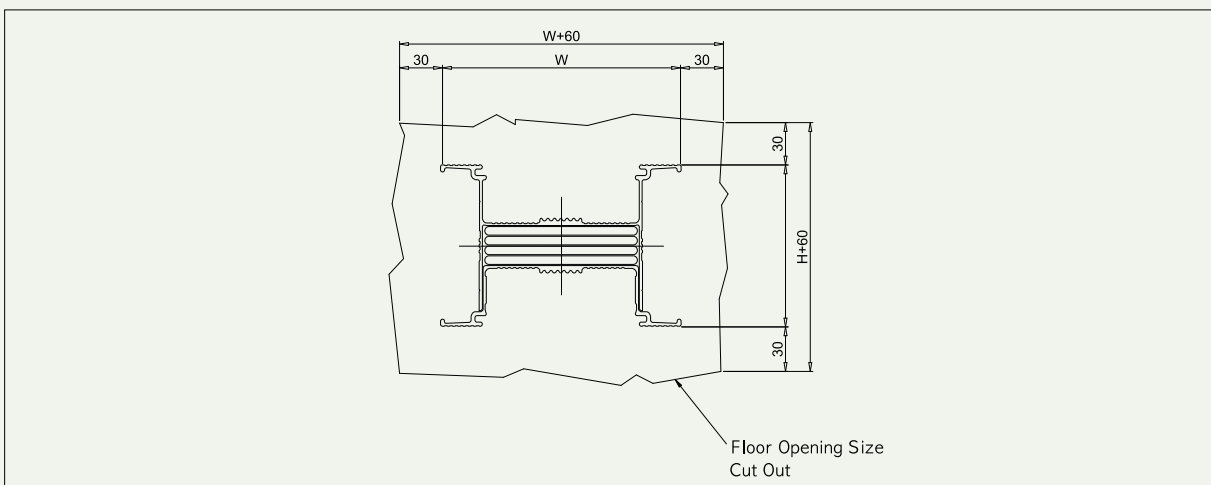

# Etc.

## The Required Minimum Distances from a Wall for Heat Dissipation and Maintenance

The required minimum distances between a busduct and a wall, or a ceiling are shown below.

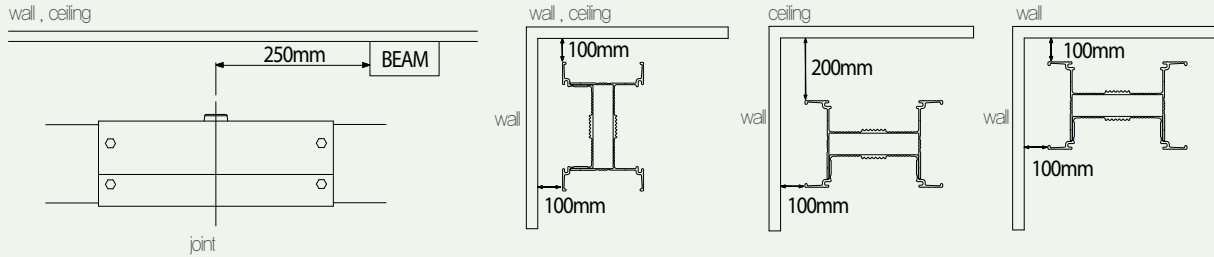

## The required minimum distances between busducts

The required minimum distances between busducts are shown below.

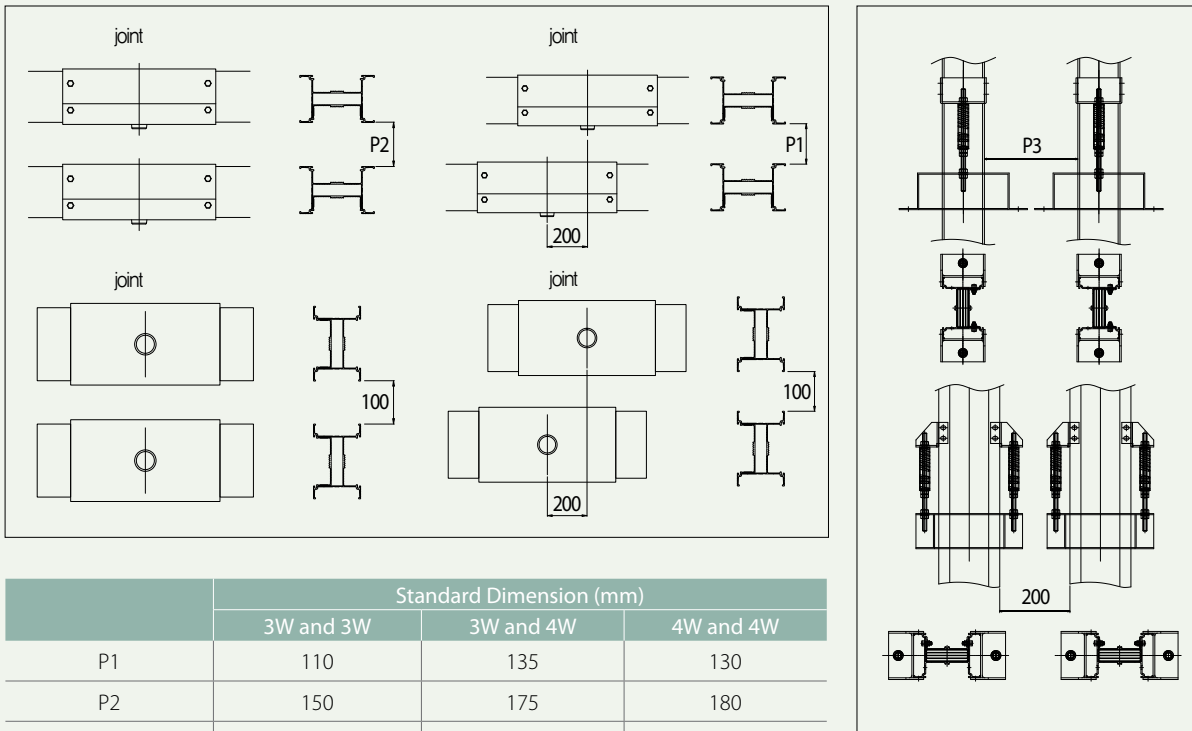

	Standard Dimension (mm)		
	3W and 3W	3W and 4W	4W and 4W
P1	110	135	130
P2	150	175	180
P3	190	215	230

\* Outdoor installation requires a further discussion with our design team about proper distance.

# Technical Data

## Impedance and Voltage Drop

The formula to measure the voltage drop of a busduct is shown below. The impedance and voltage drop values for aluminum and copper conductors are shown in the table below.

The values listed are measured between upper and middle lines at 60Hz. For a 50Hz installation, multiply the reactance (X) by 0.83.

$$V_d = I \times \sqrt{3(R \cos\theta + X \sin\theta)}$$

$V_d$  = voltage drop[V] · I = rated road amperes[A] · R = resistance[Ω] · X = reactance[Ω] / cos = power factor / sin = reactive factor

$$\text{Actual voltage Drop} = \alpha \times V_d \times \frac{\text{Actual load current}}{\text{Rated load current}} \times \frac{\text{Actual length of the line (m)}}{100m}$$

·  $\alpha$  (Load Constant)  $\alpha = 1$ , concentrated load  
(a place such as an electrical room)

$\alpha = 0.5$ , Distributed load  
(a place such as a vertical section)



· F: Flanged End (panel connections)  
· P: Plug-in Unit

Ampere(A)	Impedance( $10^{-3}\Omega$ /100m, 60Hz)			Voltage Drop(V/100m)				
	R (AC)	X	Z	0.7	0.8	0.9	1	
AL	630	12.71	4.34	13.43	13.09	13.93	14.54	13.87
	800	10.05	3.30	10.58	13.01	13.88	14.53	13.93
	1,000	7.54	2.64	7.99	12.40	13.19	13.74	13.06
	1,250	5.60	1.08	5.71	10.17	11.11	11.94	12.13
	1,450	4.63	0.89	4.71	9.74	10.65	11.44	11.62
	1,600	3.74	1.47	4.02	10.16	10.73	11.10	10.37
	1,850	3.27	1.28	3.52	10.28	10.86	11.23	10.49
	2,000	2.86	0.99	3.03	9.40	9.99	10.42	9.91
	2,250	2.52	0.87	2.67	9.31	9.91	10.33	9.83
	2,500	2.72	1.04	2.92	11.47	12.14	12.58	11.80
	2,900	2.25	0.86	2.41	10.99	11.63	12.05	11.31
	3,200	1.87	0.64	1.97	9.76	10.40	10.85	10.35
	3,700	1.63	0.56	1.73	9.88	10.52	10.98	10.47
	4,000	1.37	0.69	1.53	10.03	10.43	10.60	9.46
	4,500	1.20	0.61	1.35	9.94	10.34	10.50	9.38
	5,000	1.07	0.36	1.13	8.76	9.33	9.75	9.30
5,800	0.93	0.31	0.98	8.79	9.36	9.78	9.33	
6,300	0.80	0.44	0.91	9.56	9.88	9.96	8.72	
CU	630	13.66	2.66	13.92	12.51	13.67	14.68	14.91
	800	10.24	2.44	10.53	12.34	13.38	14.24	14.19
	1,000	7.72	1.56	7.88	11.30	12.33	13.22	13.38
	1,250	4.75	2.03	5.17	10.34	10.87	11.18	10.29
	1,450	4.00	1.71	4.35	10.10	10.61	10.92	10.06
	1,600	3.57	1.22	3.78	9.35	9.96	10.39	9.91
	1,850	3.15	1.08	3.32	9.52	10.13	10.57	10.08
	2,000	2.61	1.14	2.84	9.13	9.59	9.84	9.03
	2,250	2.30	1.00	2.51	9.07	9.52	9.77	8.96
	2,500	2.36	1.00	2.57	10.25	10.78	11.10	10.24
	2,900	1.99	0.84	2.16	10.01	10.53	10.84	10.00
	3,200	1.78	1.06	2.07	11.10	11.41	11.43	9.85
	3,700	1.56	0.93	1.82	11.29	11.61	11.63	10.02
	4,000	1.21	0.82	1.46	9.90	10.09	10.00	8.36
	4,500	1.07	0.72	1.29	9.82	10.01	9.92	8.30
	5,000	1.03	0.57	1.17	9.75	10.08	10.16	8.91
5,800	0.86	0.47	0.98	9.42	9.74	9.82	8.61	
6,300	0.75	0.54	0.92	9.92	10.06	9.92	8.18	

# Technical Data

## Short Circuit Strength

LS C&S Busduct has been tested under actual short circuit conditions according to IEC 61439-1 and 6 [(previous standard) IEC 60439-1 and 2] at KEMA and ASTA. The result and the graph are shown below.

### Phase to Phase Short Circuit Ratings

Ampere(A)	AL (kA)			CU (kA)		
	1 sec	3 sec	Peak	1 sec	3 sec	Peak
630	25	14	52.5	20	12	40
800	25	14	52.5	20	12	40
1,000	50	29	105	35	20	73.5
1,250	65	38	143	50	29	105
1,450	65	38	143	50	29	105
1,600	65	38	143	65	38	143
1,850	65	38	143	65	38	143
2,000	80	46	176	80	46	176
2,250	80	46	176	80	46	176
2,500	100	58	220	105	61	231
2,900	100	58	220	105	61	231
3,200	100	58	220	105	61	231
3,700	100	58	220	105	61	231
4,000	100	58	220	105	61	231
4,500	100	58	220	105	61	231
5,000	120	69	254	120	69	254
5,800	120	69	254	120	69	254
6,300	120	69	254	120	69	254

\* Reinforced type available

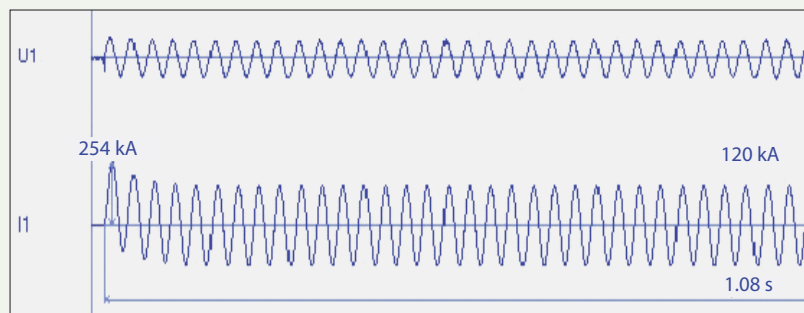

## Temperature Rise

The temperature rise limit is an important property which determines the performance of busducts. The temperature rise limit of the busduct is designed that when a busduct is operated with a rated current, the temperature limit values of the housing are within 55K as specified in IEC61439-1 and 6 [(previous standard) IEC 60439-1 and 2].

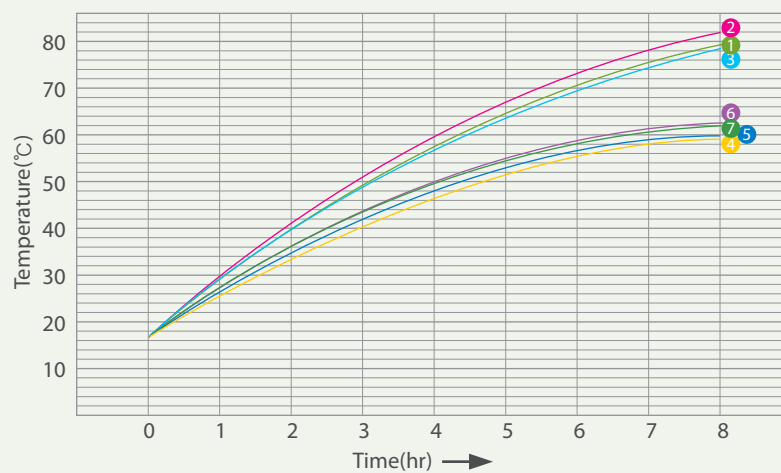
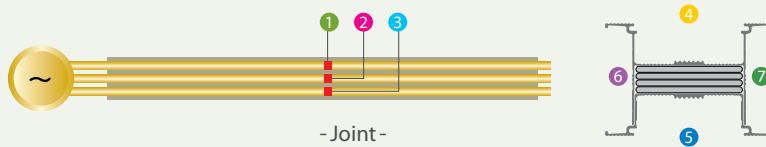

# Joint Connection

## Joint KIT

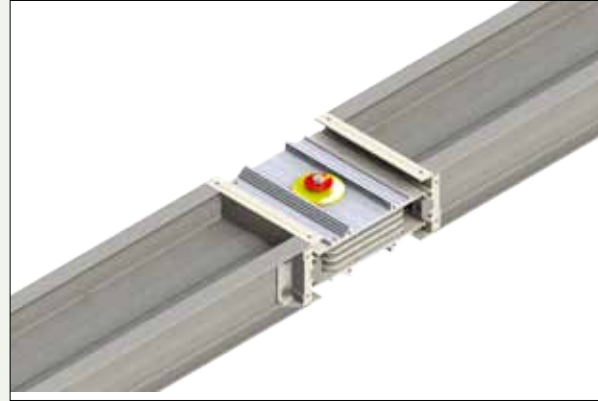
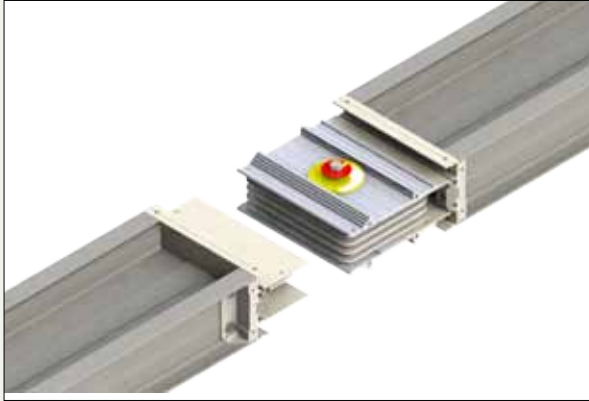

Both parts should be aligned at the top and the bottom and the left and the right as well as horizontally and vertically. (This also applies to the joint connection of the horizontal and vertical ducts.) Make sure that the joint kit is not tilted. (We recommend a jig tool for the installation.)

Using a torque wrench, slowly tighten the exposed bolt head of a double headed bolt. The head of the double headed bolt is designed to break off at 800~1000Kgf·cm. Continue tightening the exposed head until it breaks off.

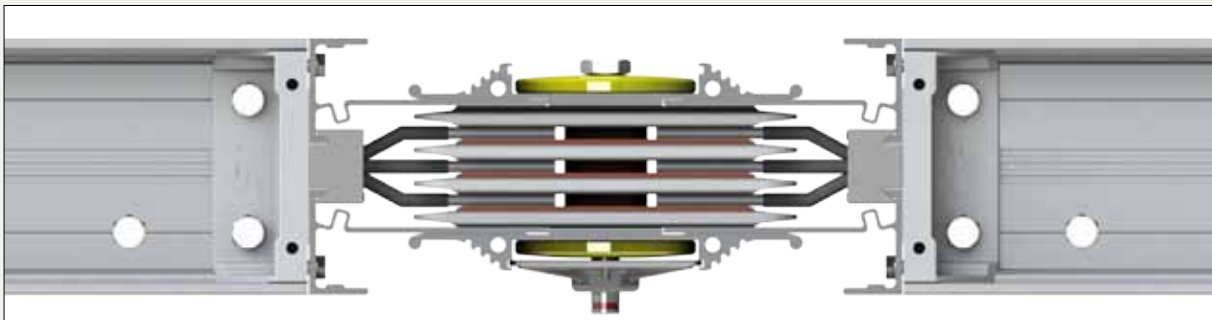

Once the exposed head and the red tag attached to it have been cut off, a red line should be visible, which means they are properly connected. Be sure to check the distance from the housing, and the gaps between the conductors at the kit after the installation.

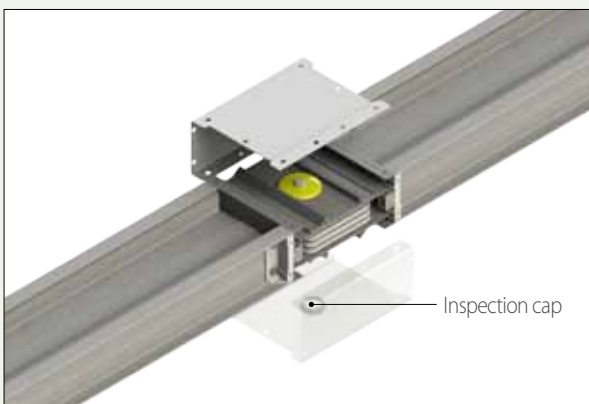

Before applying the connection cover, check the space between the end block and the holes of the connection cover. The red line should be visible through the transparent cap.

Perform the last inspection of the connection.

# Certification & Specification



KEMA KEUR (I-Series AL-AL)



KEMA KEUR (I-Series CU-AL)

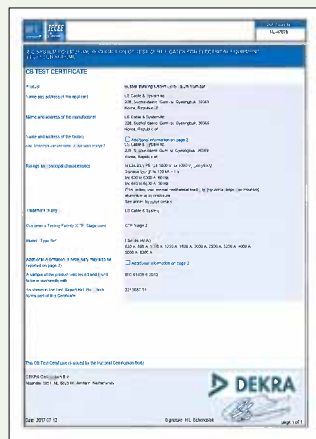

CB Certificate (I-Series AL-AL)



CB Certificate (I-Series CU-AL)



ISO 9001



ISO 14001



OHSAS 18001

Install Information

Certification & Specification

# Global Network

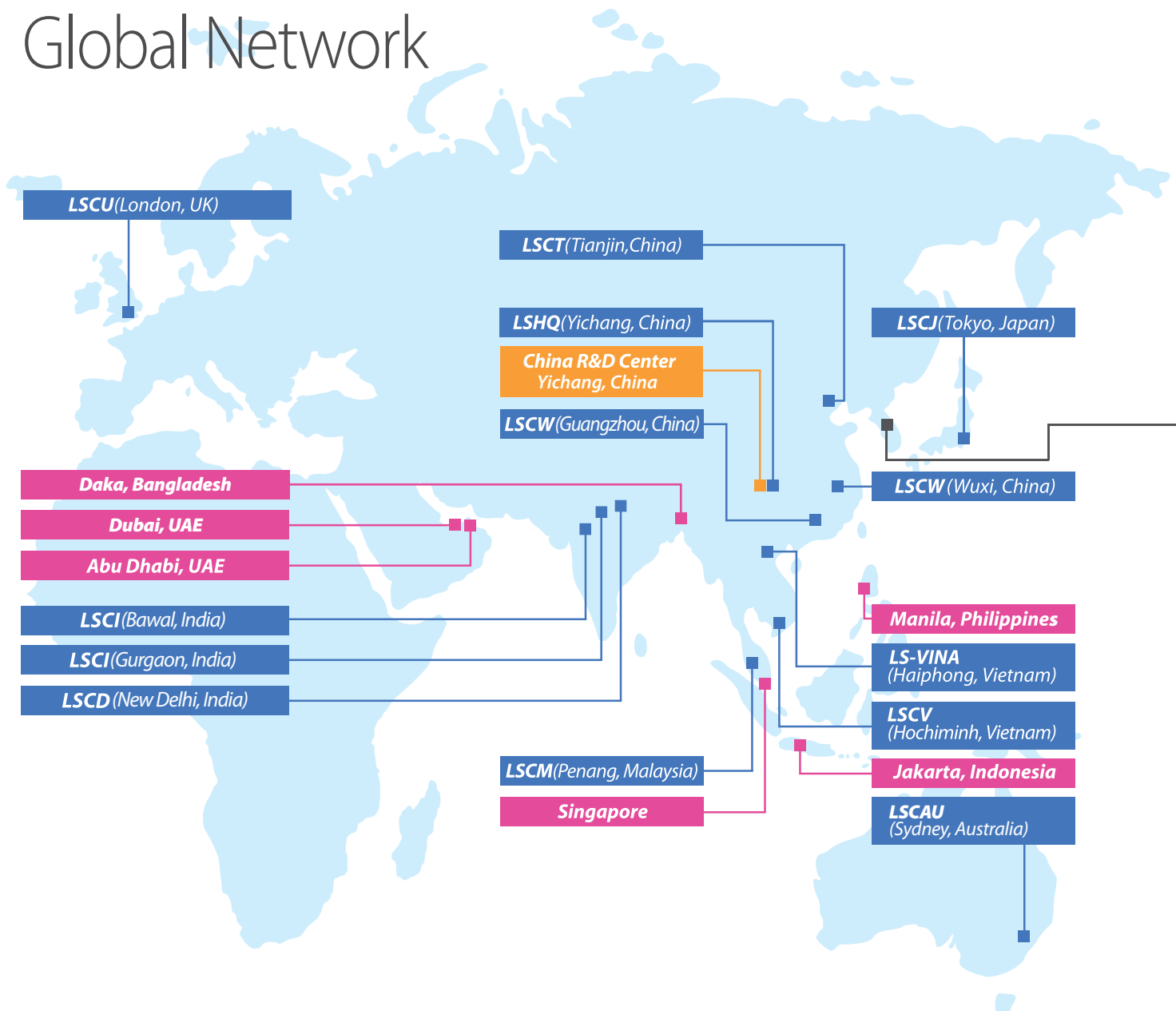

## Branches

### Abu Dhabi Office(U.A.E.)

Tel. +971-4-344-4662 Fax. +971-2-674-8781

### Dubai Office(U.A.E.)

Tel. +971-4-344-4662 Fax. +971-2-674-8781

### Singapore Office(Singapore)

Tel. +65-6342-9162-3 Fax. +65-6342-9165

### Lima Office(Peru)

Tel. +51-1-434-6433

### Jakarta Office(Indonesia)

Tel. +62-21-797-4140 / 4013 Fax. +62-21-799-3071

### Manila Office(Philippines)

Tel. +63-917-6272814

### Daka Office(Bangladesh)

Tel. +88-015-3410-0356

## Subsidiaries

### LSCA(U.S.A.) : Marketing and Sales

Tel. +1-201-944-2005 Fax. +1-201-503-8130

### LSCAU(Australia) : Marketing and Sales

Tel. +61-2-9460-0255 Fax. +61-2-9460-0355

### LSCU(U.K.) : Marketing and Sales

Tel. +44-20-8545-2640 Fax. +44-20-8545-2643

### LSCJ(Japan) : Marketing and Sales

Tel. +81-3-6205-7188 Fax. +81-3-6205-7187

### LSCD(India) : Marketing and Sales

Tel. +91-11-4106-4242

### LSHQ(China)

Tel. +86-717-667-7777

Production : EHV, LV/MV, Overhead Transmission Line, Industrial Specialty Cable & System

### LSCT(China)

Tel. +86-22-2699-7618 Fax. +86-22-2695-7617

Production : Magnet Wire

### LSCW(China)

Tel. +86-510-8811-9000 Fax. +86-510-8534-5341

Production : Automotive Wire & Cable, Bus Duct, Electronic Wire & Cable, Tube, ACF, Accessories for EHV Cable System



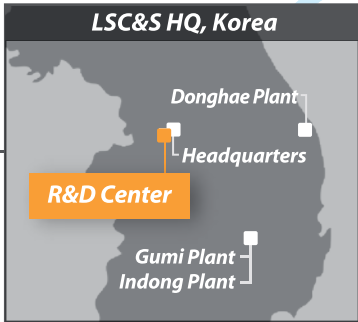
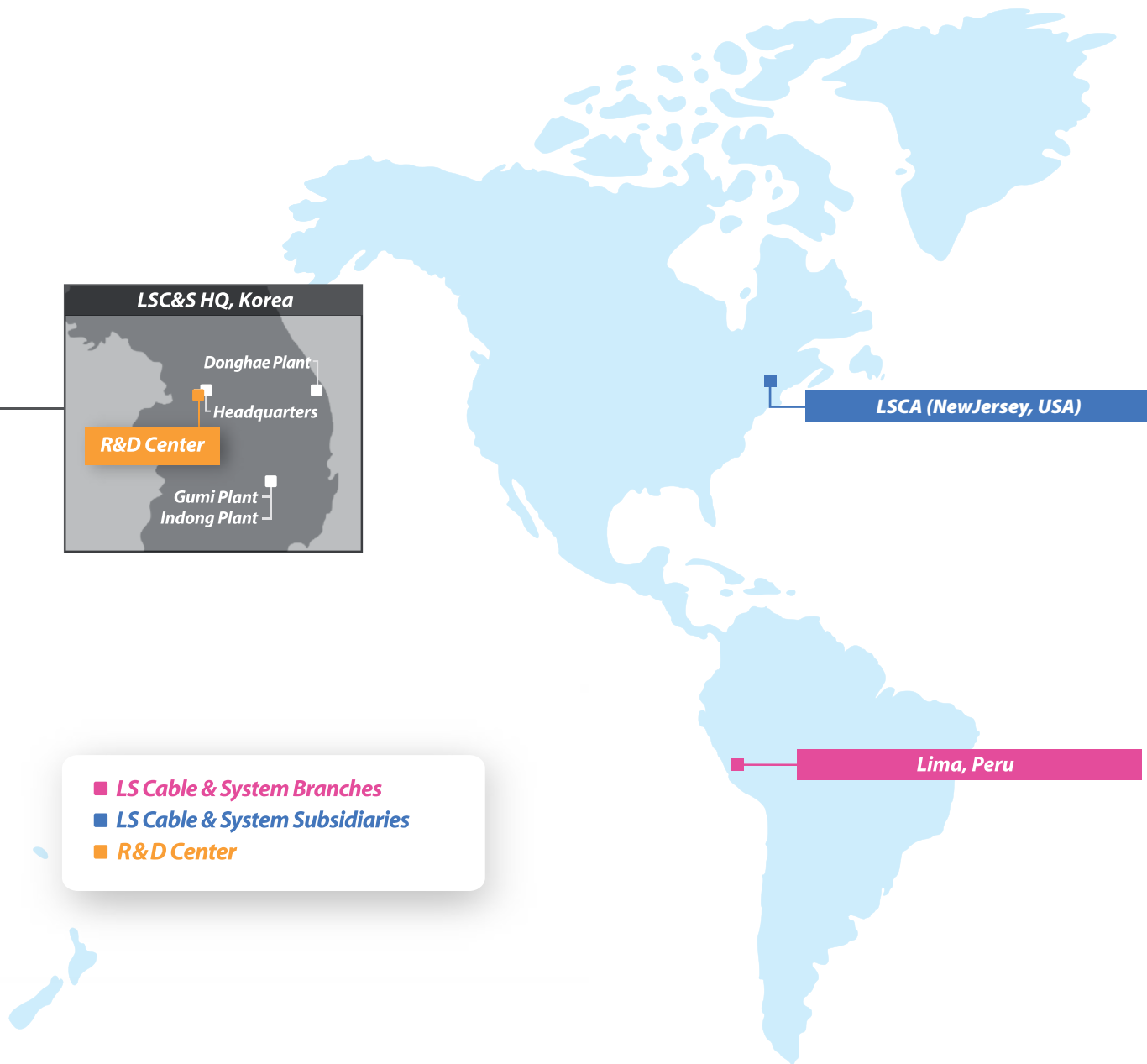

- **LS Cable & System Branches**
- **LS Cable & System Subsidiaries**
- **R&D Center**

**Beijing Office(Beijing)**

Tel. +86-10-5761-3166 Fax. +86-10-5761-3160

**Shenzhen Office(Shenzhen)**

Tel. +86-755-8275-0470~1 Fax. +86-755-8275-0545

**Guangzhou Office(Guangzhou)**

Tel. +86-20-8326-6321 Fax. +86-20-8326-6270

**LS-VINA(Vietnam)**

Tel. +84-31-354-0141 Fax. +84-31-354-0142

Production : EHV, LV/MV, ACSR, OPGW, SCR

**LSCV(Vietnam)**

Tel. +84-61-356-9140 Fax. +84-61-356-9148

Production : Low Voltage Cable, UTP

**LSCM(Malaysia)**

Tel. +60-4-588-9609 Fax. +60-4-588-9607

Production : Magnet Wire

**LSCI(India)**

**Gurgaon: Marketing & Sales**

Tel. +91-124-428-5800~4 Fax. +91-124-428-5805

**Bawal**

Tel. +91-128-426-4267 Fax. +91-128-426-4364

Production : RF Feeder Cable, Network Solution, EHV, LV/MV, OPGW

**China R&D Center**

Tel. +86-717-667-7777

**Korea Operations**

**Headquarter**

Tel. +82-2-2189-9114

**Gumi Plant**

Tel. +82-54-469-7114

Production : Power Cable up to 500kV, OHTL, OPGW, Data Cable, RF Feeder System, Copper Rod, Magnet Wire

**Indong Plant**

Tel. +82-54-469-1053

Production : Industrial Cable & Module, Optical Cable, Aluminum Materials

**Donghae Plant**

Tel. +82-33-820-3114

Production : Submarine Cable, Industrial Specialty Cable

**R&D Center**

Tel. +82-31-450-8114

Greater Value Together  
**LS Cable & System**

**LS** Cable & System  
[www.lscns.com](http://www.lscns.com)

**LS Busduct System**

12F, LS Tower, 127 LS-ro, Dongan-gu, Anyang-si, Gyeonggi-do, 14119, Korea  
Tel. +82-2-2189-9669 Fax. +82-2-6969-5424

©2018 LS Cable & System Ltd. All right reserved. This product or document is protected by copyright and distributed under licenses restricting its use, copying, distribution, and decompilation. No part of this product or document may be reproduced in any form by any means without prior written authorization of LS Cable & System and its licensors, if any. Products shown on this catalog are subject to change without any prior notice.